

Analog Front End with High Gain PGA

FEATURES

- Supply Voltage +2.7V to +3.6V
- Ambient Operating Temperature -40°C to +125°C
- ADC Resolution 16-Bit (No missing codes)
- Data Rate 0.814k to 6.51kps⁽¹⁾
- Input mode Differential
Single-ended⁽²⁾
Pseudo-differential⁽³⁾
- PGA 1V/V to 512V/V
- System Calibration for offset & gain drift
- Conversion mode Single / Continuous
- Interface SPI
- Package DFN8 (ESON8-V1) / 2.3mm x 2.3mm
SSOP8 / 3.5mm x 6.4mm

- (1) Case of single conversion.
(Continuous conversion is three times the data rate.)
- (2) PGA2 can be used only. (PGA1 cannot be used.)
Two channels of VINP & VINN can be used.
- (3) Bias voltage of VINP & VINN is common to VDD / 2.
Input Signal can be used VINP only.

APPLICATION

- Pressure sensors
- Flowmeters
- Thermostat
- PLC
- Digital Panel Meters

EQUIVALENT CIRCUIT BLOCK DAIGRAM

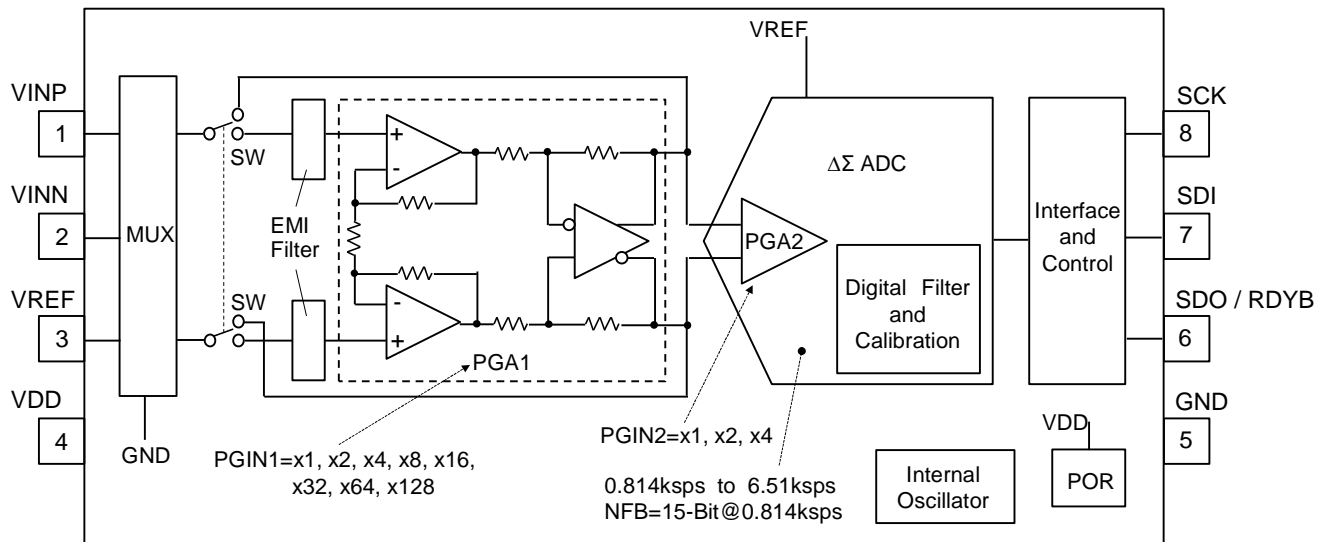

GENERAL DESCRIPTION

NJU9103 is a small size AFE with up to 512 times internal PGA (Programmable Gain Amplifier).

Internal 16-bit $\Delta\Sigma$ type A / D converter can perform conversion rates from 0.814kps to 6.51kps.

The customer can choose internal A/D converter's input, among single-ended input, differential input and pseudo-differential input.

NJU9103 can set the optimum gain to the pressure sensor, flow sensor by a wide range of gain setting.

Sensor of the offset is corrected by internal D / A converter. Various parameters (such as gain, conversion rate, correction) settings can be easily set in the SPI communication from an external MCU.

NJU9103 will contribute to the customer's development time reduction and the series product release. NJU9103 is also can be mounted in a narrow application footprint by a small 8-pin package. Package is preparing the DFN and SSOP

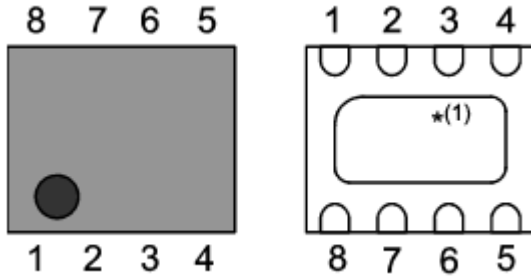
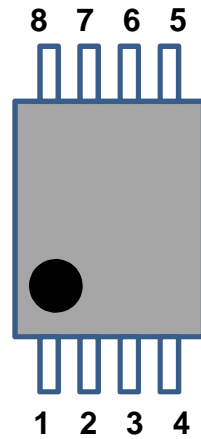
■ PIN CONFIGURATION
DFN8 (ESON8-V1)

SSOP8

PIN NO.	SYMBOL	PIN TYPE
1	VINP	+INPUT for differential mode / INPUT1 for Single-ended mode
2	VINN	-INPUT for differential mode / INPUT2 for single-ended mode
3	VREF	Reference Voltage Input
4	VDD	Supply Voltage
5	GND	GND
6	SDO / RDYB	SPI serial data output / RDYB output
7	SDI	SPI serial data input
8	SCK	SPI serial clock input
*(1)	Exposed PAD DFN8(ESON8-V1) only	Exposed PAD on backside connects to GND.

MARK INFORMATION

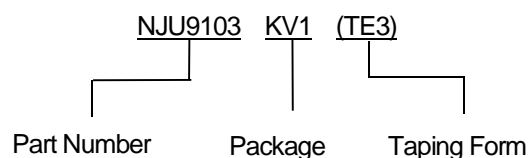
DFN8 (ESON8-V1)



SSOP8

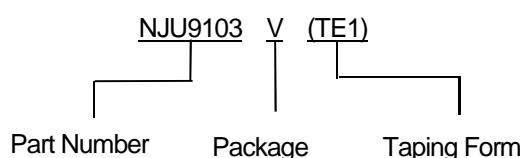

ORDERING INFORMATION

PART NUMBER	PACKAGE OUTLINE	RoHS	Halogen-Free	TERMINAL FINISH	MARKING	WEIGHT (mg)	MOQ (pcs)
NJU9103KV1	DFN8 (ESON8-V1)	yes	yes	Sn-2Bi	9103	7.2	3,000
NJU9103V	SSOP8	yes	yes	Sn-2Bi	9103	42	2,000

ABSOLUTE MAXIMUM RATINGS

PARAMETER	SYMBOL	RATINGS	UNIT
Power Supply Voltage	VDDabso	5 ⁽⁴⁾	V
Power Dissipation (T _a =25°C)	P _D	DFN8 (ESON8-V1) : 580 ⁽⁵⁾ / 1785 ⁽⁶⁾ SSOP8 : 460 ⁽⁵⁾ / 595 ⁽⁶⁾	mW
Analog Input Voltage	V _{IN}	-0.3 to (VDD+0.3) ⁽⁷⁾	V
Operating Temperature Range	T _{opr}	-40 to +125	°C
Storage Temperature Range	T _{stg}	-40 to +150	°C

- (4) The difference between the absolute maximum power supply voltage and the operating power supply voltage is small. Please be careful so that the operating power supply voltage does not exceed the absolute maximum supply voltage by spike voltage.
- (5) Mounted on glass epoxy board.
(114.3 x 76.2 x 1.57mm: based on EIA/JEDEC standard, 2Layers FR-4, with Exposed Pad)
- (6) Mounted on glass epoxy board
(114.3 x 76.2 x 1.6mm: based on EIA/JEDEC standard, 4Layers FR-4, with Exposed Pad)
- (7) Input pin is connected to the clamp diode to the power supply pin. When the input signal exceeds the supply rails 0.3V or more (below the GND rail 0.3V or more), the input current must be limited to less than 10mA.

RECOMMENDED OPERATING CONDITIONS

PARAMETER	SYMBOL	RATINGS	UNIT
Power Supply Voltage	VDD	+2.7 to +3.6	V
Operating Temperature Range	T _{opr}	-40 to +125	°C
Storage Temperature Range	T _{stg}	-40 to +150	°C

■ ELECTRICAL CHARACTERISTICS (Analog Input)

Unless otherwise specified, all limits ensured for $T_a=+25^{\circ}\text{C}$, $V_{DD}=3.3\text{V}$, $GND=0\text{V}$, $V_{REF}=0.5 \times V_{DD}$, $PGAIN1=PGAIN2=1$, $VCIN2=0.5 \times V_{DD}$, $DR=0.814\text{ksp}$ s or 1.63ksp s

PARAMETER	SYMBOL	TEST CONDITION	MIN.	TYP.	MAX.	UNIT
Analog Input 1 (PGA1=unused, PGA2=used, PGAIN2=1 or 2 or 4)						
Differential Input Voltage Range 1	VDIN1		-	$\pm V_{REF} / (PGAIN2)$	-	V
Common Mode Input Voltage Range 1	VCIN1		GND	-	VDD	V
Input Impedance 1	ZIN1	FMOD = 1.25MHz PGAIN2 = 1	-	400	-	k
		FMOD = 1.25MHz PGAIN2 = 2 or 4	-	200	-	k
Common Mode Rejection Ratio 1	CMRR1	PGAIN2 = 1	70	90	-	dB

Analog Input 2 (PGA1, 2=used, PGAIN1=1 or 2 or 4 or 8 or 16 or 32 or 64 or 128, PGAIN2=1 or 2 or 4)

Differential Input Voltage Range2	VDIN2	PGAIN1 \geq 2	-	$(\pm V_{REF}) / (PGAIN1 \times PGAIN2)$	-	V
Common Mode Input Voltage Range 2	VCIN2		0.1	-	VDD -1.2	V
Input Impedance 2	ZIN2		-	100	-	M
Common Mode Rejection Ratio 2	CMRR2	PGAIN1 = 2 PGAIN2 = 1	40	60	-	dB
		PGAIN1 = 2 PGAIN2 = 1 CHOP= ON DR = 0.407ksp	70	90	-	dB

■ ELECTRICAL CHARACTERISTICS (Reference Voltage Input)

Unless otherwise specified, all limits ensured for $T_a=+25^{\circ}\text{C}$, $V_{DD}=3.3\text{V}$, $GND=0\text{V}$

PARAMETER	SYMBOL	TEST CONDITION	MIN.	TYP.	MAX.	UNIT
Reference Voltage	VREF		$0.5 \times V_{DD}$	-	VDD	V
Input Impedance 3	ZIN3	FMOD = 1.25MHz PGAIN2 = 1 or 2	-	180	-	k
		FMOD = 1.25MHz PGAIN2 = 4	-	300	-	k

■ ELECTRICAL CHARACTERISTICS (Internal Oscillator)

Unless otherwise specified, all limits ensured for $T_a=+25^{\circ}\text{C}$, $V_{DD}=3.3\text{V}$, $GND=0\text{V}$

PARAMETER	SYMBOL	TEST CONDITION	MIN.	TYP.	MAX.	UNIT
OSC Frequency	FOSC		1.75	2.5	3.25	MHz

■ ELECTRICAL CHARACTERISTICS (Programmable Gain Amplifier)

 Unless otherwise specified, all limits ensured for $T_a=+25^{\circ}\text{C}$, $V_{DD}=3.3\text{V}$, $GND=0\text{V}$

PARAMETER	SYMBOL	TEST CONDITION	MIN.	TYP.	MAX.	UNIT
PGA1 Gain	PGAIN1		-	1, 2, 4, 8, 16, 32, 64, 128,	-	V/V
PGA2 Gain	PGAIN2		-	1, 2, 4	-	V/V

■ ELECTRICAL CHARACTERISTICS (Analog to Digital Converter)

 Unless otherwise specified, all limits ensured for $T_a=+25^{\circ}\text{C}$, $V_{DD}=3.3\text{V}$, $GND=0\text{V}$, $V_{REF}=0.5 \times V_{DD}$,
 $PGAIN1=PGAIN2=1$, $VCIN2=0.5 \times V_{DD}$

PARAMETER	SYMBOL	TEST CONDITION	MIN.	TYP.	MAX.	UNIT
Resolution	N	No missing codes ⁽⁸⁾	16			Bit
Data Rate	DR	Single Conversion ⁽⁹⁾	0.814k, 1.63k, 3.26k, 6.51k			sps
Clock Frequency	FMOD (MDCK)	$F_{MOD} = F_{OSC}/2$	0.875	1.25	1.625	MHz
Integral Non Linearity	INL	best-fit-line method ⁽¹⁰⁾ $V_{REF} = V_{DD}$ $PGAIN1 = 2$	-	± 30	± 60	ppm
Offset Error	OE	$PGAIN1 = 128$ Input-Referred Offset	-	200	-	μV
		$PGAIN1 = 128$ Input-Referred Offset CHOP=ON	-	± 2	± 10	μV
Gain Error	GE	SSOP8 $PGAIN1 = 128$ $DR = 3.26\text{ksps}$	1.0	2.5	4.0	%
		DFN8 (ESON8-V1) $PGAIN1 = 128$ $DR = 3.26\text{ksps}$	0.5	2.0	3.5	
Noise Free Bit ⁽¹¹⁾	NFB	$VDIN2 = 0\text{V}$ $V_{REF} = 3.3\text{V}$ $DR = 0.814\text{ksps}$ ⁽⁸⁾	14	15	-	Bit
		$VDIN2 = 0\text{V}$ $V_{REF} = 3.3\text{V}$ $DR = 1.63\text{ksps}$ ⁽⁸⁾	13	14	-	Bit

(8) This parameter is not production tested, please refer Typical Characteristics.

(9) There is no latency by one settling behavior.

(10) Guaranteed by design evaluation and several points test

 (11) NFB represents the ADC output code variations 6.6σ with the differential input shorted.

■ ELECTRICAL CHARACTERISTICS (Power Supply / Supply Current)

 Unless otherwise specified, all limits ensured for $T_a=+25^{\circ}\text{C}$, $V_{DD}=3.3\text{V}$, $GND=0\text{V}$

PARAMETER	SYMBOL	TEST CONDITION	MIN.	TYP.	MAX.	UNIT
Power Supply Voltage	VDD		2.7	3.3	3.6	V
Supply Current 1	IDD	PGA OFF	1.65	2.3	3.0	mA
		PGA ON	3.0	4.0	5.0	mA
Supply Current 2	IDD _{pd}	Power Down Mode	12.75	17.00	21.25	μA

■ ELECTRICAL CHARACTERISTICS (Digital I/Os)

 Unless otherwise specified, all limits ensured for $T_a=+25^{\circ}\text{C}$, $V_{DD}=3.3\text{V}$, $GND=0\text{V}$

PARAMETER	SYMBOL	TEST CONDITION	MIN.	TYP.	MAX.	UNIT
Positive-going input threshold voltage	V_{th+}		-	1.6	-	V
Negative-going input threshold voltage	V_{th-}		-	1.2	-	V
Input voltage hysteresis	V_{hyst}	VDD = 3.0V	-	280	-	mV
High-level input voltage	V_{ih}		0.7 x VDD	-	-	V
Low-level input voltage	V_{il}		-	-	0.3 x VDD	V
High-level output voltage	V_{oh}	I _{oh} max.= 6mA	0.8 x VDD	-	-	V
Low-level output voltage	V_{ol}	I _{ol} max.= 6mA	-	-	0.4	V

■ ELECTRICAL CHARACTERISTICS (Serial Peripheral Interface)

PARAMETER	SYMBOL	MIN.	TYP.	MAX.	UNIT
SPI clock frequency	F_{sck}	-	-	10	MHz
High period of the SCK clock	t_1	45	-	-	ns
Low period of the SCK clock	t_2	45	-	-	ns
SDI input data setup time	t_3	5	-	-	ns
SDI input data hold time	t_4	5	-	-	ns
SDO / RDYB output data setup time	t_5	0	-	40	ns
SDO / RDYB output data hold time	t_6	10	-	50	ns
Reset time	t_{rstw}	-	-	400	ns

- The SPI of AC timing is shown in the figure below. At the maximum, it is the communication of 10Mbps.
- Load of SDO / RDB terminal is assumed to 40pF
- CSB terminal (chip select terminal) is fixed at a low level inside the chip.
- In order to connect a plurality of NJU9103, it requires SPI bus that is equally the number of NJU9103.

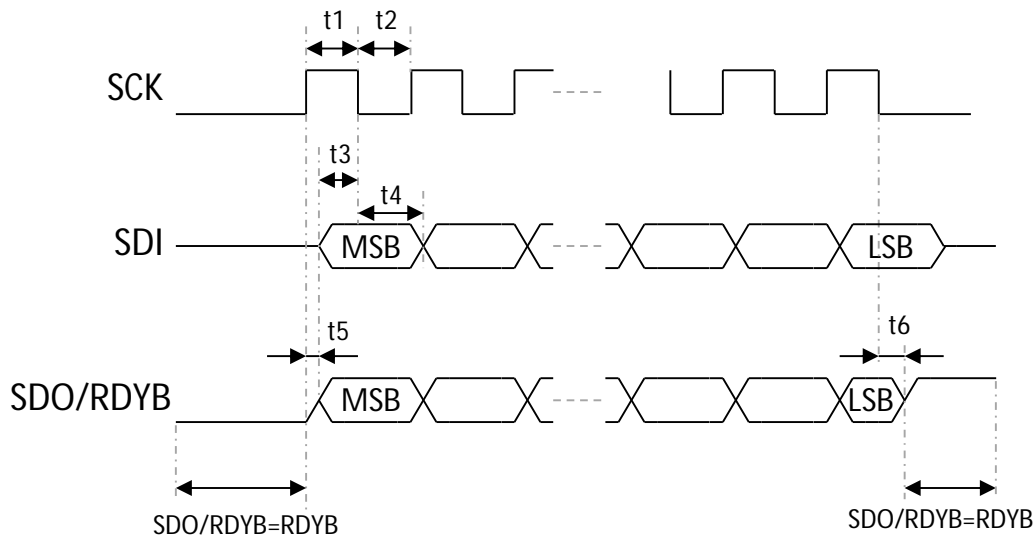

REGISTER DESCRIPTION

NJU9103 has register (list shown below) which can access it through SPI bus.

REGISTER ADDRESS	REGISTER NAME	BIT							
		[7]	[6]	[5]	[4]	[3]	[2]	[1]	[0]
0x0	CTRL	RDYB	OV / CHSEL [2]	CHSEL [1:0]		MODE [3:0]			
0x1	ADCDATA0	ADCDATA [15:8]							
0x2	ADCDATA1	ADCDATA [7:0]							
0x3	PGACONF	-	-	PGA2GAIN [1:0]		PGA1EN	PGA1GAIN [2:0]		
0x4	CLKCONF	-	-	CLKDIV [1:0]		-	OSR [2:0]		
0x5	DACCONF	-	-	CALDACEN	CALDAC [4:0]				
0x6	OPTION0	CHIPID [6:0]							AUTOSLP
0x7	Not used	-							
0x8	GAIN0	GAIN [23:16]							
0x9	GAIN1	GAIN [15:8]							
0xA	GAIN2	GAIN [7:0]							
0xB	OFFSET0	OFFSET [23:16]							
0xC	OFFSET1	OFFSET [15:8]							
0xD	OFFSET2	OFFSET [7:0]							
0xE	Not used	-							
0xF	Not used	-							

< View of the register table >

REGISTER NAME								
BIT	[7]	[6]	[5]	[4]	[3]	[2]	[1]	[0]
BIT NAME								
R / W								
RESET								

R / W: Bit of attribute (Write or Read)

- R (Read Only) : Read only
- W (Write Only) : Write only (At the time of read, return "0".)
- RW (Read Write) : Read & Write

Reset: Reset value in register

Set to the reset value by SPI reset command and power-on.

EVERY REGISTER DESCRIPTION
CTRL Register

Register Address: 0x0

CTRL								
BIT	[7]	[6]	[5]	[4]	[3]	[2]	[1]	[0]
BIT NAME	RDYB	OV	-		MODE [3:0]			
R / W	R	R / W	RW		RW			
RESET	1	0	0x0		0x0			

BIT	BIT NAME	FUNCTION
[7]	RDYB	Data Ready Flag. When conversion data is updated, this bit is set to "0". When "ADCDATA0" is read, this bit is set to "1". 0: Ready 1: Not ready
[6]	OV	Overflow flag. When conversion data is overflow, this bit is set to "1". When "ADCDATA0" is read, this bit is set to "1". 0: Valid 1: Overflow (Data is invalid)
[5:4]	CHSEL [2:0]	Analog input channel setting. Please refer to Table 1 for details.
[3:0]	MODE	Operation mode setting. When this bit is read, returns the current configuration state. Please refer to Table 2 for details.

Table 1 CHSEL [2:0]

CHSEL [2:0]	Positive	Negative
0x0	VINP	VINN
0x1	Not used ⁽¹²⁾	
0x2	VINP	GND
0x3	VINN	GND
0x4	VREF	GND
0x5	GND	GND
0x6	VINN	VINN
0x7	Not used ⁽¹²⁾	

(12) Please do not absolutely use the "Not used" code. It will be the cause of failure.

Table 2 MODE [3:0]

MODE [3:0]	Operation	Processing
0x0	idle	Conversion operation waiting state
0x1	Not used ⁽¹³⁾	-
0x2	Single conversion	Convert once the input channel that is selected in the CHSEL [2:0]. After the conversion, the operation is "idle (0x0)" state. Using the value of the "OFFSET0, 1, 2" register.
0x3	Continuous conversion	Convert continuous the input channel that is selected in the CHSEL[2:0]. Until the operation is set to "idle (0x0)", conversion will continue. Using the value of the "OFFSET0, 1, 2" register.
0x4	Single conversion + CHOP	This is the same as "Single conversion (0x2)", but the data rate is 1/2. Not using the value of the "OFFSET0, 1, 2" register.
0x5	Continuous conversion + CHOP	This is the same as "Continuous conversion (0x3)", but the data rate is 1/3. Not using the value of the "OFFSET0, 1, 2" register.
0x6	Not used ⁽¹³⁾	-
0x7	Not used ⁽¹³⁾	-
0x8	Calibration ADC offset	When you run this command, the following will be processed automatically. - PGA1 turn off, PGA2 gain is set to "x1". - Input is fixed to GND/GND internally, ADC offset will be calibrated. - Coefficient is stored in the offset register. In this case, the CHSEL [2:0] setting is invalid.
0x9	Calibration ADC gain	When you run this command, the following will be processed automatically. - PGA1 turn off, PGA2 gain is set to "x1". - Input is fixed to VREF/GND internally, ADC gain will be calibrated. - Coefficient is stored in the gain register. In this case, the CHSEL [2:0] setting is invalid.
0xA	Calibration PGA offset ⁽¹⁴⁾	When you run this command, the following will be processed automatically. However, before the execution of this command to set the PGA1 / PGA2 gain. - Input is fixed to VNN/VNN internally, PGA offset will be calibrated. - Coefficient is stored in the offset register. In this case, the CHSEL [2:0] setting is invalid.
0xB	Not used ⁽¹³⁾	-
0xC	Calibration system offset	This command is calibrated in a state in which to connect the sensor. When you run this command, the following will be processed automatically. However, before the execution of this command to set the input channel. - Input is selected by CHSEL [2:0], system offset will be calibrated. - Coefficient is stored in the offset register.
0xD	Calibration system gain	This command is calibrated in a state in which to connect the sensor. When you run this command, the following will be processed automatically. However, before the execution of this command to set the input channel. - Input is selected by CHSEL [2:0], system gain will be calibrated. - Coefficient is stored in the gain register.
0xE	Not used ⁽¹³⁾	-
0xF	Boot	Read-only. It shows the state from the reset to change to idle (0x0). After the initial setting, automatically shifts to the "idle (0x0)".

(13) Please do not absolutely use the "Not used" code. It will be the cause of failure.

(14) Before the commands are executed, please set PGA1/ 2 of the gain to PGACONF register.

ADCDATA0 / ADCDATA1 Register

Register Address: 0x1 / 0x2

BIT	ADCDATA0								ADCDATA1							
	Register Address: 0x1								Register Address: 0x2							
BIT	[7]	[6]	[5]	[4]	[3]	[2]	[1]	[0]	[7]	[6]	[5]	[4]	[3]	[2]	[1]	[0]
BIT NAME	ADCDATA [15:0]															
R / W	R															
RESET	-															

BIT	BIT NAME	FUNCTION
ADCDATA0 [7:0] + ADCDATA1 [7:0]	ADCDATA [15:0]	Store the converted data of the ADC. ⁽¹⁵⁾ Conversion data is expressed as a signed 16-bit. - Negative full-scale voltage is 0x8000 - When the input voltage is zero 0x0000 - Positive full-scale voltage will be 0x7FFF. (in decimal -32768 to +32767) Please be sure to perform a read in order of ADCDATA0, ADCDATA1.

- (15) Relationship of conversion data ADCDATA and the analog input voltage V_{in} is as the following equation.
 (It assumed that the offset error and gain error are zero.)

$$ADCDATA = \frac{V_{in}}{2 \times VREF} \times PGAIN1 \times PGAIN2 \times 2^{16} = \frac{V_{in}}{VREF} \times PGAIN1 \times PGAIN2 \times 2^{15}$$

PGACONF Register

Register Address: 0x3

PGACONF							
BIT	[7]	[6]	[5]	[4]	[3]	[2]	[1] [0]
BIT NAME	-	-	PGA2GAIN		PGA1EN	PGA1GAIN	
R / W	-	-	RW		RW	RW	
RESET	-	-	0x0		0	0x0	

BIT	BIT NAME	FUNCTION
[5:4]	PGA2GAIN	Gain setting of PGA2. 0x0: x1 0x1: x2 0x2: x4 0x3: Not used ⁽¹⁶⁾
[3]	PGA1EN	Setting ON / OFF of PGA1. 0: OFF 1: ON
[2:0]	PGA1GAIN	Gain setting of PGA1. 0x0: x1 0x1: x2 0x2: x4 0x3: x8 0x4: x16 0x5: x32 0x6: x64 0x7: x128

(16) Please do not absolutely use the "Not used" code. It will be the cause of failure.

CLKCONF Register

Register Address: 0x4

CLKCONF							
BIT	[7]	[6]	[5]	[4]	[3]	[2]	[1] [0]
BIT NAME	-	-	CLKDIV		-	OSR	
R / W	-	-	RW		-	RW	
RESET	-	-	0x0		-	0x3	

BIT	BIT NAME	FUNCTION
[5:4]	CLKDIV ⁽¹⁷⁾	Setting of the ADC operating clock frequency (F _{MOD}). F _{OSC} is the operating clock of the internal OSC. 0x0: F _{OSC} / 2 0x1: F _{OSC} / 4 0x2: F _{OSC} / 8 0x3: F _{OSC} / 16
[2:0]	OSR	Setting of the oversampling ratio of the digital filter 0x0: 64 0x1: 128 0x2: 256 0x3: 512 0x4 to 0x7: Not used ⁽¹⁸⁾

(17) Data rate is derived by the following equation. It will be the data rate of a single conversion.

$$DR = F_{OSC} \times \frac{1}{OSR} \times \frac{1}{2^{(CLKDIV+1)}} \times \frac{1}{3}$$

If F_{OSC} is 2.5MHz of (TYP.), Conversion data rate will be set in the table below.

OSR	Date Rate [sps]			
	CLKDIV=0 (Recommendation)	CLKDIV=1 ^(*)	CLKDIV=2 ^(*)	CLKDIV=3 ^(*)
512	0.814k	0.407k	0.204k	0.102k
256	1.63k	0.814k	0.407k	0.204k
128	3.26k	1.63k	0.814k	0.407k
64	6.51k	3.26k	1.63k	0.814k

(*) Design guarantee.

(18) Please do not absolutely use the "Not used" code. It will be the cause of failure.

DACCONF Register

Register Address: 0x5

DACCONF									
BIT	[7]	[6]	[5]	[4]	[3]	[2]	[1]	[0]	
BIT NAME	-	-	CALDACEN	CALDAC [4:0]					
R / W	-	-	RW	RW					
RESET	-	-	0	0x00					

BIT	BIT NAME	FUNCTION
[5]	CALDACEN	Setting ON/OFF of DAC 0: OFF (Power down) 1: ON
[4:0]	CALDAC ⁽¹⁹⁾	The sensor offset is corrected to add or subtract the DAC voltage from the output PGA1. CALDAC is a signed 5-bit code, MSB is the sign bit.

(19) NJU9103 contains internal calibration DAC.

When the gain of NJU9103 is large and the offset of sensor is 10mV, the data conversion does not work correctly by the constraints of the D-range of the analog circuit. To correct this, DAC will generate a voltage opposite to offset voltage of the sensor.

A simplified block diagram of the input section of the NJU9103 is shown below.

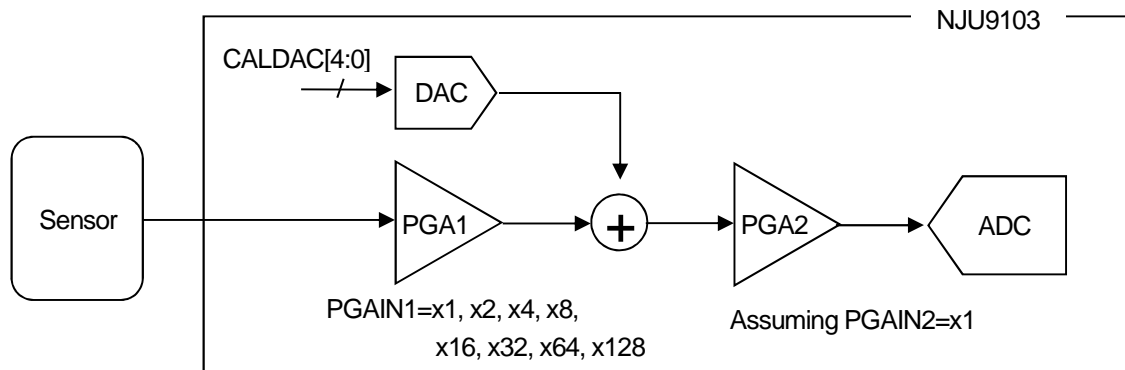

The correction range and resolution (voltage step) of sensor are changed by PGA1 gain.

It can be derived by the following equation.

$$\text{"Sensor offset correction value"} = \text{"Resolution"} \times \text{CALDAC[4:0]}$$

(Note) Design assurance at VDD = 3.3V.

The variation of the resolution (error) is about $\pm 15\%$.

PGAIN1	Resolution[mV]
x16	8.8
x32	5.8
x64	3.7
x128	2.2

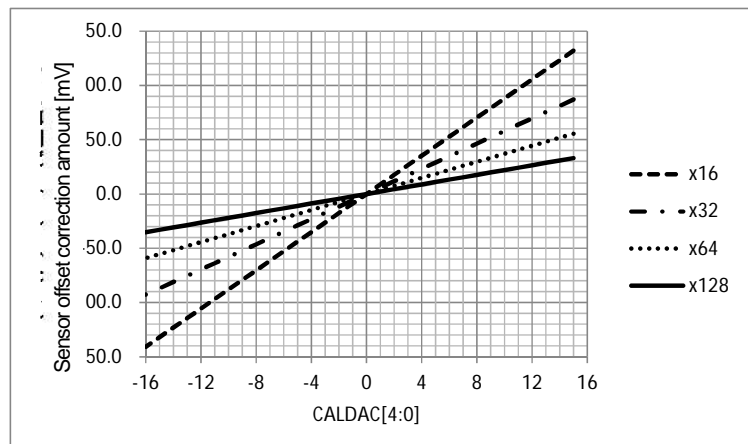

OPTION0 Register

Register Address: 0x6

OPTION0								
BIT	[7]	[6]	[5]	[4]	[3]	[2]	[1]	[0]
BIT NAME	CHIPID [6:0]							AUTOSLP
R / W	R							RW
RESET	0x00							0

BIT	BIT NAME	FUNCTION
[7:1]	CHIPID	Used to identify the chip.
[0]	AUTOSLP	When MODE[3:0] is idle (0x0), set to ON / OFF of analog block 0: ON (Wait) 1: OFF (Power down) When the customer change AUTOSLP from 1 to 0, conversion start is necessary to start-up time of the analog block.

GAIN0 / GAIN1 / GAIN2 Register

Register Address: 0x8, 0x9, 0xA

BIT	GAIN0								GAIN1								GAIN2							
	Register Address: 0x8								Register Address: 0x9								Register Address: 0xA							
BIT	7	6	5	4	3	2	1	0	7	6	5	4	3	2	1	0	7	6	5	4	3	2	1	0
BIT NAME	GAIN [23:0]																							
R / W	RW																							
RESET	0x01								0x00								0x00							

BIT	BIT NAME	FUNCTION
GAIN0 [7:0] + GAIN1 [7:0] + GAIN2 [7:0]	GAIN [23:0]	Gain coefficient derived in gain calibration or the external writing gain coefficient. 18-bit unsigned coefficient, GAIN [23:18] is always "0". The customer can do the external writing gain coefficient, when internal clock is active only. Please set to "0" AUTOSLP bit of OPTION0 register.

OFFSET0 / OFFSET1 / OFFSET2 Register

Register Address: 0xB, 0xC, 0xD

BIT	OFFSET0								OFFSET1								OFFSET2							
	Register Address: 0xB								Register Address: 0xC								Register Address: 0xD							
	7	6	5	4	3	2	1	0	7	6	5	4	3	2	1	0	7	6	5	4	3	2	1	0
BIT NAME	OFFSET [23:0]																							
R / W	RW																							
RESET	0x00								0x00								0x00							

BIT	BIT NAME	FUNSTION
OFFSET0 [7:0] + OFFSET1 [7:0] + OFFSET2 [7:0]	OFFSET [23:0]	Offset coefficient derived in offset calibration or the external writing offset coefficient. 20-bit signed coefficient, OFFSET [23:20] is sign-extended value. ⁽²⁰⁾ The customer can do the external writing offset coefficient, when internal clock is active only. Please set to "0" AUTOSLP bit of OPTION0 register.

(20) Sign-extended: If the sign is (-) fill the 1 in the free space. If the sign is (+) fill the "0" in the free space

- In the case of -4 in decimal 8-bit is "11111100".
16-bit sign extension is "11111111 11111100".
- In the case of +4 in decimal 8-bit is "00000100"
16-bit sign extension is "00000000 00000100"

APPLICATION NOTE / GLOSSARY
Power up sequence

When the power supply is started, the reset cancellation is valid.

After a reset cancellation, the circuit will start operating.

The time from the reset cancellation to the operation start state is required waiting time of about 30 μ s.

(The rise time of power signal is not included.)

Effective resolution, Noise Free Bit (NFB)

Data Rate (DR) is speed at the time of single conversion (1 settling).

Output code variation σ is the effective resolution in the VINP and VINN connected to VDD/2, 6.6 σ is the NFB.

< Condition >

- FMOD=1.25MHz
- VDD=3.3V, GND=0V
- VREF=3.3V
- Differential input
- T_a=+25°C

DR vs. Effective resolution (Unit: bit)

DR [sps]	PGA OFF	PGA ON									
		x1	x2	x4	x8	X16	x32	x64	x128	x256	x512
0.814k	16	16	16	16	16	16	16	16	15.5	15	14
1.63k	16	16	16	16	16	16	16	16	15	14	13
3.26k	15.5	15.5	15.5	15.5	15.5	15.5	15.5	15.5	14.5	13.5	12.5
6.51k	14	14	14	14	14	14	14	14	13.5	13	11.5

DR vs. NFB (Unit: bit)

DR [sps]	PGA OFF	PGA ON									
		x1	x2	x4	x8	x16	x32	x64	x128	x256	x512
0.814k	15	15	15	15	14.5	14.5	14.5	13.5	13	12	11
1.63k	14	14	14	14	14	14	14	13.5	12.5	11.5	10.5
3.26k	13	13	13	13	13	13	13	12.5	12	11	10
6.51k	11	11	11	11	11	11	11	11	11	10	9

■ Digital filter frequency characteristic

The output of the $\Delta\Sigma$ modulator is converted to a digital value of high resolution by a digital filter (third-order Sinc filter).

Frequency characteristics will change depending on the data rate.

When the conversion data rate (DR) is 6.51ksps, 3.26ksps, 1.63ksps, 0.814ksps, frequency characteristics of the digital filter is shown below. Characteristic is the case of F_{MOD}=1.25MHz.

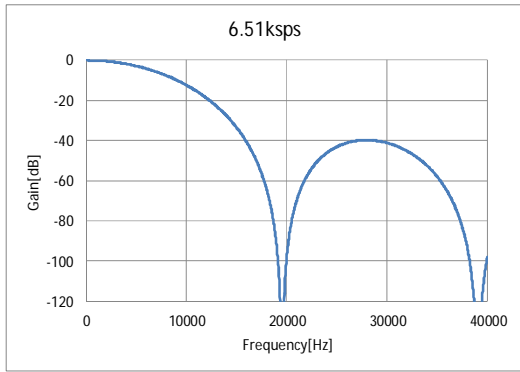

DR=6.51ksps

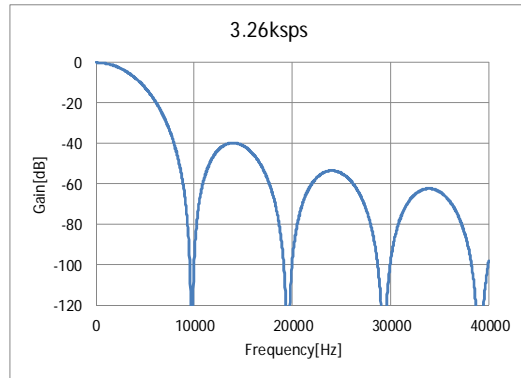

DR=3.26ksps

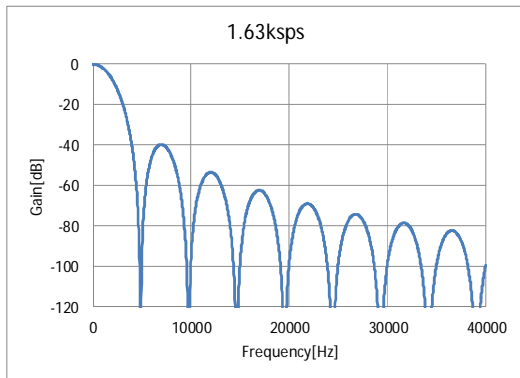

DR=1.63ksps

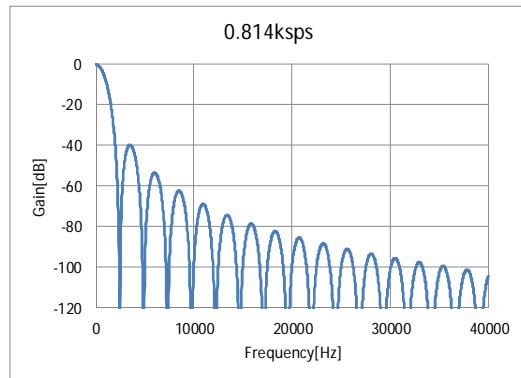

DR=0.814ksps

It has a first notch in the frequency of the data rate x 3.
Or later, it has a notch to the integer multiple of the position.⁽²¹⁾

(e.x.) In the case 3.26ksps (Figure of right)

Position of the notch

1. 9.8kHz (3.26kHz x 3 x 1)
2. 19.6kHz (3.26kHz x 3 x 2)
3. 29.3kHz (3.26kHz x 3 x 3)
4. 39.1kHz (3.26kHz x 3 x 4)

⋮

(N) 3.26kHz x 3 x N (N is an integer)

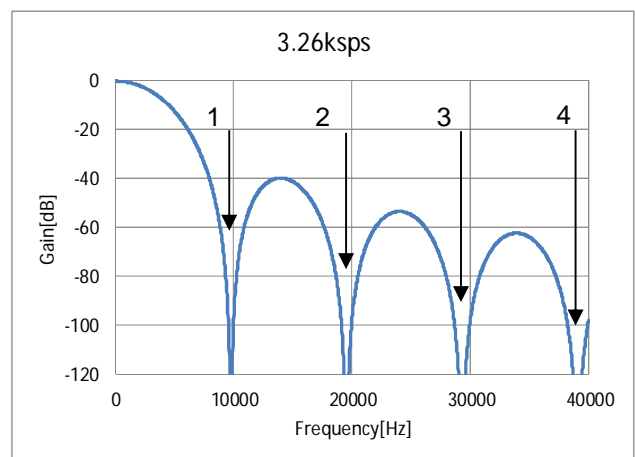

DR=3.26ksps

(21) Position of the notch varies in proportion to the frequency of the F_{MOD}

F_{MOD} is $\pm 25\%$ variation. Position of the notch is likely to vary $\pm 25\%$ from the above figure.

■ System Example

An example of an application that uses the bridge sensor is shown below.

In order to draw the best performance of Analog-to-Digital Converter (ADC), the customer is careful about the printed circuit board (PCB) layout pattern and a bypass capacitor placement.

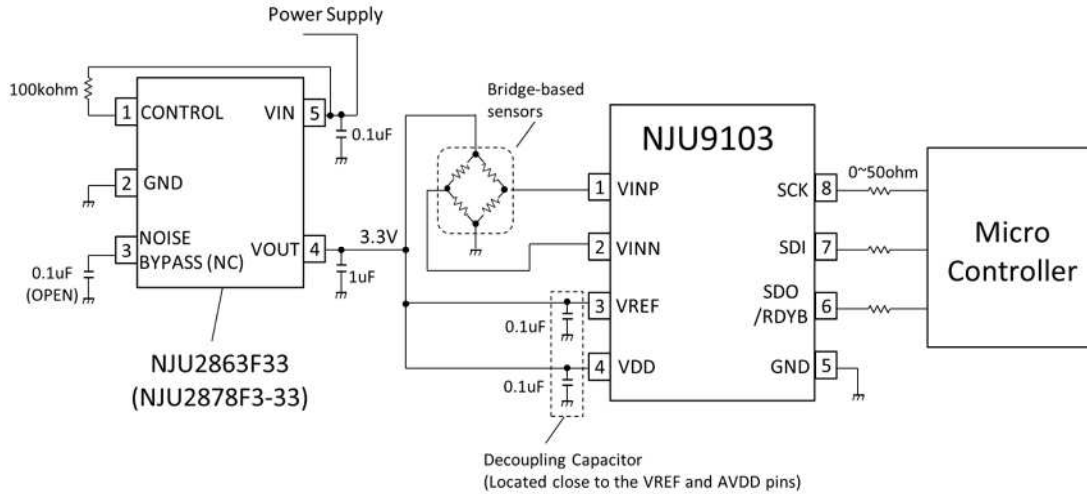

The PCB layout pattern example of NJU9103 is shown below.

GND of decoupling capacitor and GND of NJU9103 make to equipotential as much as possible.

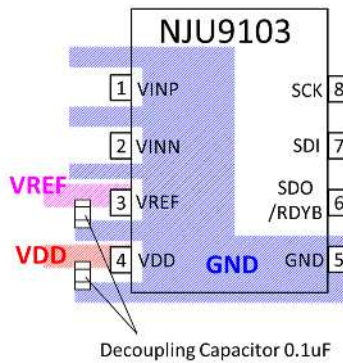

If the noise source and the NJU9103 is mounted on the same PCB, GND of the noise source and GND of NJU9103 separate until just before the GND Pin (connector).

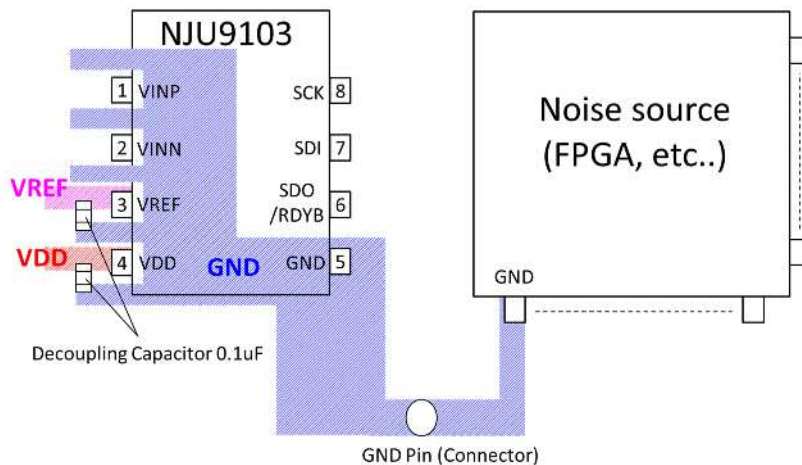

■ Conversion Control

Set the conversion operation by MODE [3: 0] bit of CTRL register.

MODE[3:0]	OPERATION
0x0	Idle
0x1	Not used
0x2	Single conversion
0x3	Continuous conversion
0x4	Single conversion + CHOP
0x5	Continuous conversion + CHOP
0x6, 0x7	Not used
0x8	Calibration ADC offset
0x9	Calibration ADC gain
0xA	Calibration PGA offset
0xB	Not used
0xC	Calibration system offset
0xD	Calibration system gain
0xE	Not used
0xF	Boot

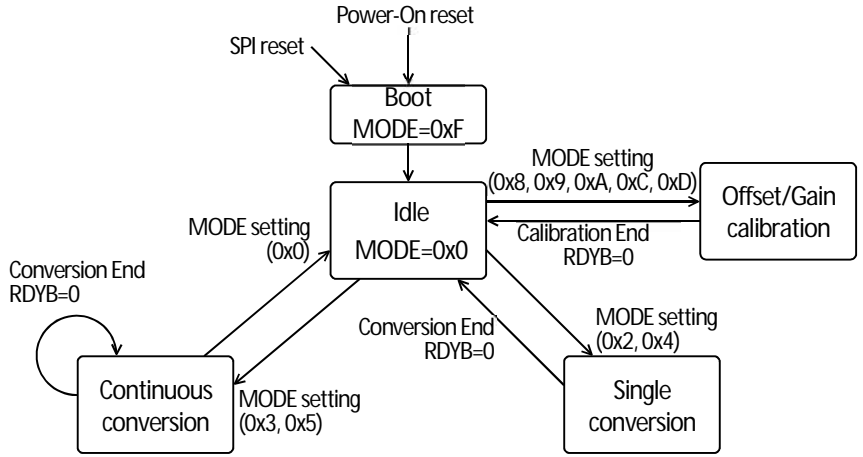

< Definition of time >

(1) ADC conversion time of basic : T_{adc}

$$T_{adc} = \frac{OSR}{F_{MOD}}$$

OSR : Over Sampling Rate
F_{MOD} : Clock Frequency of ADC

(2) Calculation time for data correction (after ADC conversion) : T_{cal}

$$T_{cal} = \frac{40}{F_{OSC}}$$

F_{OSC} : Clock Frequency of Internal Oscillator

(3) Calculation time for gain coefficient (after gain calibration) : T_{div}

$$T_{div} = \frac{70}{F_{OSC}}$$

(4) Setup time : T_s

When the analog block is ON (AUTOSLP bit of OPTION 0 register = "0"), setting the MODE [3: 0] bit in CTRL register to operation mode starts operation after T_s (about 10 μ s). The case where the MODE [3: 0] bit is switched from "sleep (0x0)" to "single conversion (0x2)" is shown below.

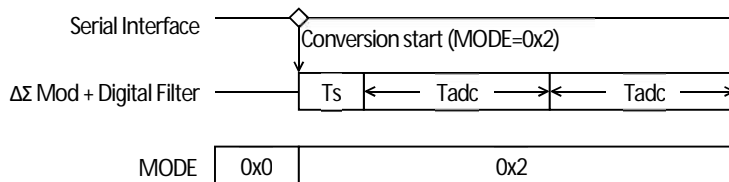

(5) Startup wait time : T_{wu}

Waiting time of T_{wu} (about 70 μ s) is required when changing the analog block from OFF to ON (AUTOSLP bit from "1" to "0"). The figure below shows the case where the MODE [3: 0] bit is switched from "sleep (0x0)" to "single conversion (0x2)".

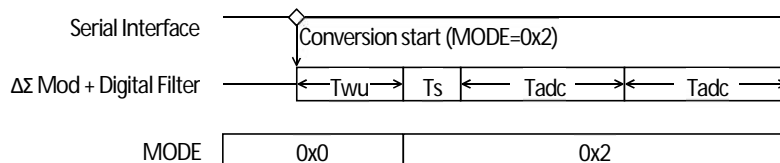

1. Single Conversion operation (MODE[3:0] = 0x2)

It is the basic conversion of NJU9103.

Even if the input signal is switched by the multiplexer (external), waiting time for converted data is unnecessary.

(1 settling, zero latency)

When the conversion cycle is long, the recommended usage is that converting once and power-down the remaining period. So, the consumption current of NJU9103 can be reduced. It is the optimum conversion method for "switching input signals with multiplexer" and "low power consumption".

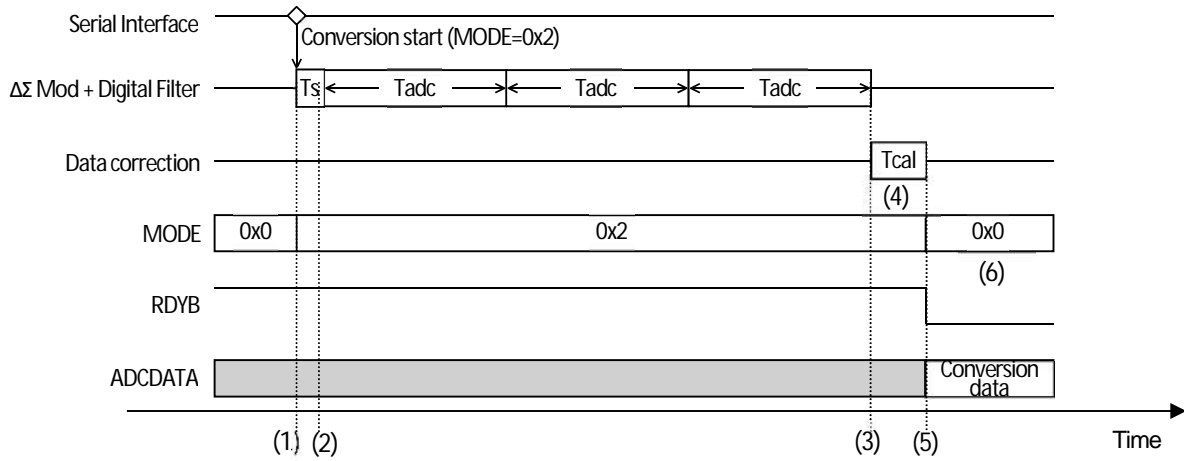

STEP	DETAILS
(1)	Set to single conversion. (MODE [3: 0] bit in CTRL register = "0x2")
(2)	After the set-up time (Ts), start the conversion.
(3)	Conversion completed with conversion time (3 x Tadc). The conversion data is the result of the convolution integration of 3 x Tadc. (ΔΣ Mod + Digital Filter)
(4)	Data is corrected with calculation time (Tcal).
(5)	Conversion data stored in ADCDATA register. At that time, RDYB bit changes from "1" to "0".
(6)	Shift to Idle state. (MODE[3:0] bit= "0x0")

In NJU9103, the data rate is specified by the following formula. (Single conversion)

$$DR = F_{OSC} \times \frac{1}{OSR} \times \frac{1}{2^{(CLKDIV+1)}} \times \frac{1}{3}$$

The conversion data rate (DR) is DR_all when Ts and Tcal are considered. (In the table below, CLKDIV=0)

OSR	DR [sps]	3xTadc(=1/DR) [s]	3xTadc+Ts+Tcal [s]	DR_all (=1/(3xTadc+Ts+Tcal)) [sps]
512	0.814k	1.23m	1.26m	0.794k
256	1.63k	0.614m	0.640m	1.56k
128	3.26k	0.307m	0.333m	3.00k
64	6.51k	0.154m	0.180m	5.56k

2. "Single conversion + CHOP" operation (MODE[3:0] = 0x4)

Single conversion performs single conversion twice. By change VINP and VINN at the second conversion, the NJU9103 offset can be removed in real time. The change of VINP and NINN is done automatically by the internal switch.

With single conversion, it is the optimum conversion method for "when you want to calibrate the offset in real time".
Though, the data rate is half of single conversion.

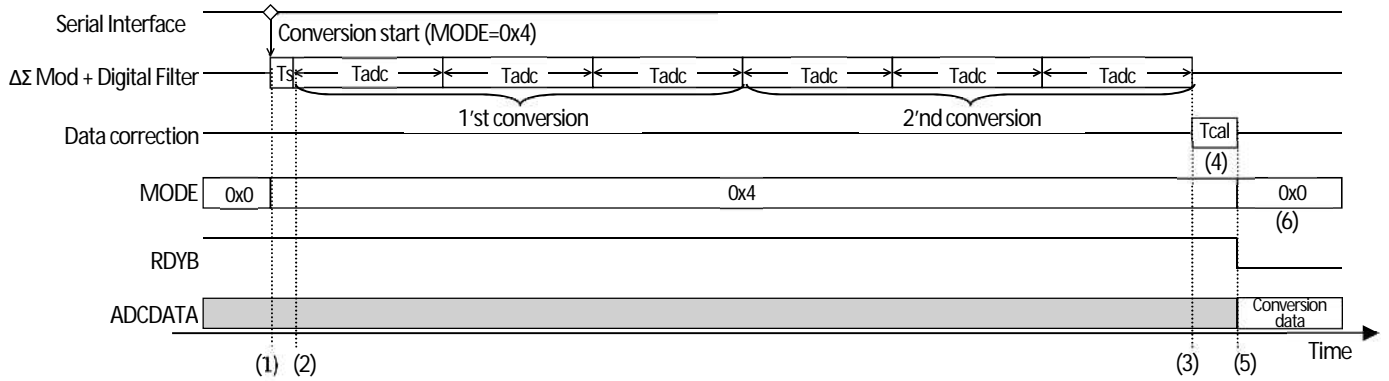

STEP	DETAILS
(1)	Set to single conversion + CHOP. (MODE [3: 0] bit in CTRL register = "0x4")
(2)	After the set-up time (T_s), start the conversion.
(3)	Conversion completed in conversion time ($6 \times T_{adc}$). The conversion data is the result of the convolution integration of $6 \times T_{adc}$. (1'st & 2'nd conversion of " $\Delta\Sigma$ Mod + Digital Filter".)
(4)	Data is corrected in calculation time (T_{cal}).
(5)	Conversion data stored in ADCDATA register. At that time, RDYB bit changes from "1" to "0".
(6)	Shift to Idle state. (MODE[3:0] bit= "0x0")

3. Continuous conversion operation (MODE[3:0] = 0x3)

When input signals are switched by the multiplexer, the same waiting time as the first conversion (conversion A) is required. When input signal is not switched by multiplexer, wait time after the second conversion (conversion B) is unnecessary.

It is the optimum conversion method for "when input is not switched by multiplexer" and "when you want to maximize data rate". The data rate is three times that of single conversion.

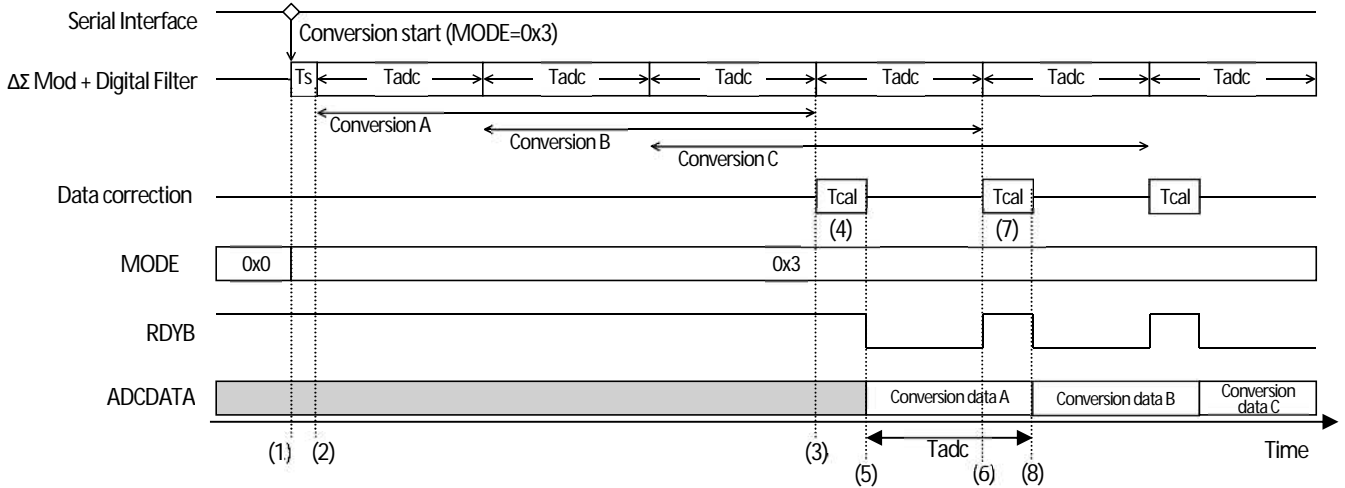

STEP	DETAILS
(1)	Set to continuous conversion. (MODE [3: 0] bit in CTRL register = "0x3")
(2)	After the set-up time (Ts), start the conversion.
(3)	Conversion A (1'st) completed in conversion time (3 x Tadc). The conversion data A is the result of the convolution integration of conversion A ("3 x Tadc" of $\Delta\Sigma$ Mod + Digital Filter")
(4)	Data is corrected in calculation time (Tcal)
(5)	Conversion data A (1'st) stored in ADCDATA register. At that time, RDYB bit changes from "1" to "0".
(6)	After completion of conversion B (2'nd), RDYB bit changes from "0" to "1". The conversion data B is the result of the convolution integration of conversion B ("3 x Tadc" of $\Delta\Sigma$ Mod + Digital Filter)
(7)	Data is corrected in calculation time (Tcal).
(8)	Conversion data B (2'nd) stored (overwrite) in ADCDATA register. At that time, RDYB bit changes from "1" to "0".

Repeat steps (5) to (8) until the operation mode is set to idle (MODE [3: 0] bit is set to "0x0").

4. “Continuous conversion + CHOP” operation (MODE[3:0] = 0x5)

By changing VINP and VINN every "3 x Tadc", the NJU9103 offset can be removed in real time. The change of VINP and VINN is done automatically by the internal switch.

When input signals are switched by the multiplexer, the same waiting time as the first conversion (conversion A) is required. When input signal is not switched by multiplexer, wait time after the second conversion (conversion B) is unnecessary.

As with “single conversion + CHOP” operation, offset of whole chip can be calibrated in real time.

It is the optimal conversion method for "when you want to calibrate offsets in real time" with continuous conversion. Though, the data rate is 1/3 of continuous conversion. (Same data rate as single conversion)

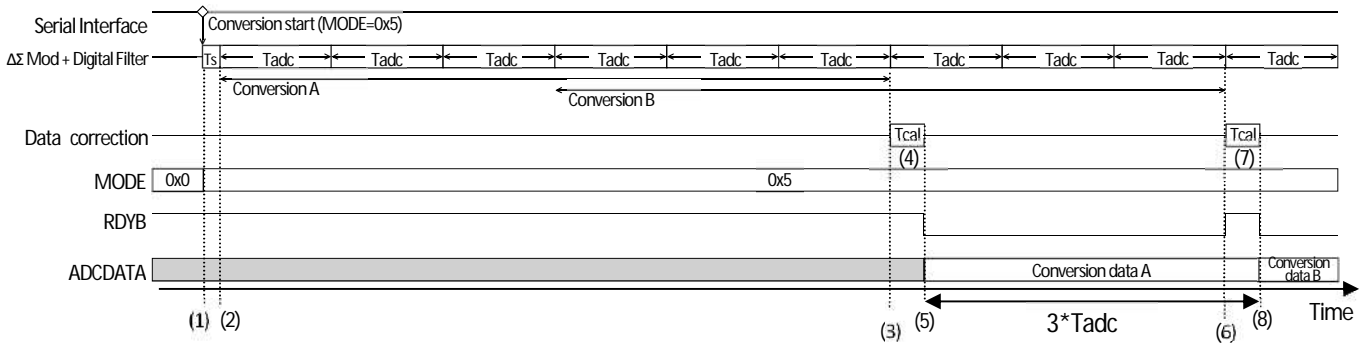

STEP	DETAILS
(1)	Set to continuous conversion + CHOP. (MODE [3: 0] bit in CTRL register = "0x5")
(2)	After the set-up time (Ts), start the conversion.
(3)	Conversion A (1'st) completed in conversion time (6 x Tadc). The conversion data A is the result of the convolution integration of conversion A ("6 x Tadc" of ΔΣ Mod + Digital Filter)
(4)	Data is corrected in calculation time (Tcal).
(5)	Conversion data A (1'st) stored in ADCDATA register. At that time, RDYB bit changes from "1" to "0".
(6)	After completion of conversion B (2'nd), RDYB bit changes from "0" to "1". The conversion data B is the result of the convolution integration of conversion B ("6 x Tadc" of ΔΣ Mod + Digital Filter)
(7)	Data is corrected in calculation time (Tcal).
(8)	Conversion data B (2'nd) stored (overwrite) in ADCDATA register. At that time, RDYB bit changes from "1" to "0".

Repeat steps (5) to (8) until the operation mode is set to idle (MODE [3: 0] bit is set to "0x0").

5. Offset calibration operation (MODE[3:0] = 0x8, 0xA, 0xC)

Timing is almost the same as single conversion operation.

Calculate the offset amount and save it in the OFFSET register (OFFSET0, OFFSET1, and OFFSET2).

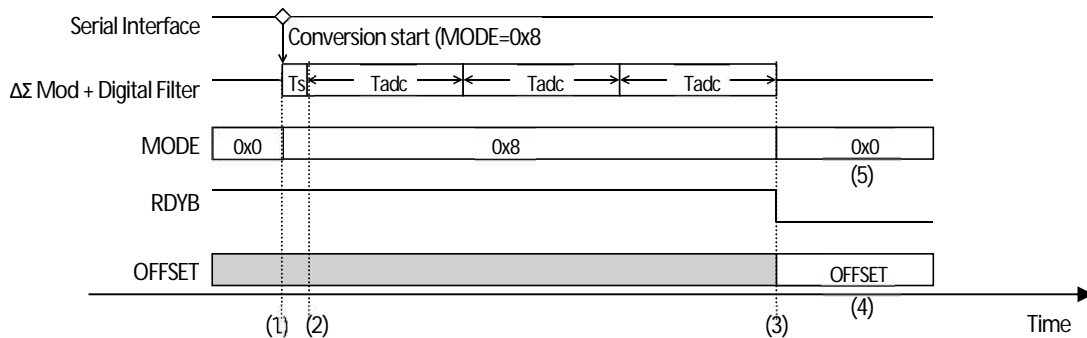

STEP	DETAILS
(1)	Set to offset calibration. (MODE [3: 0] bit in CTRL register = 0x8 or 0xA or 0xC)
(2)	After the set-up time (T_s), start the conversion.
(3)	Conversion is complete in conversion time ($3 \times T_{adc}$).
(4)	Conversion data stored in OFFSET register (OFFSET0, OFFSET1, OFFSET2). At that time, RDYB bit changes from "1" to "0".
(5)	Shift to Idle state. (MODE[3:0] bit= "0x0")

The NJU 9103 supports the following three types of offset calibration operation.

A. Internal offset calibration (MODE[3:0] = 0x8)

When the internal offset calibration command is executed, the following processing is automatically performed.

- Set PGA1 to OFF and set the PGA2 gain to "x1".
- Applying GND internally to IN^+ and IN^- of the ADC to calculate the offset.
- Store calculated offset in OFFSET registers.

B. PGA1 offset calibration (MODE[3:0] = 0xA)

Set the gain of PGA1 and PGA2 before executing the PGA1 offset calibration command.

When the PGA1 offset calibration command is executed, the following processing is automatically performed.

- Connect VINN to the plus and minus inputs of PGA 1 and calculate the offset.
- Store calculated offset in OFFSET registers.

C. System offset calibration (MODE[3:0] = 0xC)

CHSEL [2: 0] bit selects the input channel.

When the system offset calibration command is executed, the following processing is automatically performed.

- Calculate the offset using the input channel selected with the CHSEL [2: 0] bits.
- Store calculated offset in OFFSET registers.

6. Gain calibration operation (MODE[3:0] = 0x9, 0xD)

Timing is almost the same as “single conversion + CHOP” operation.

Calculate the gain factor and save it in the GAIN register (GAIN0, GAIN1, and GAIN2).

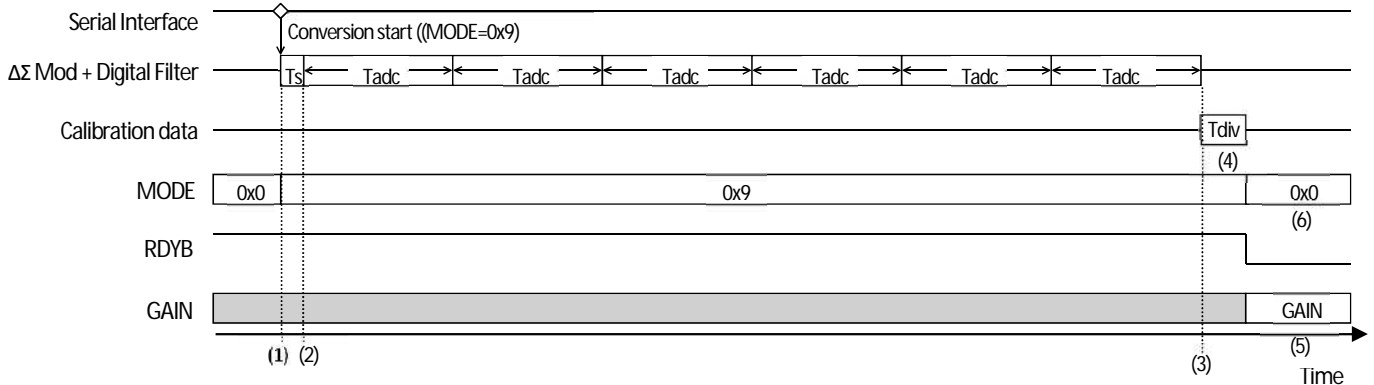

STEP	DETAILS
(1)	Set to gain calibration. (MODE [3: 0] bit in CTRL register = 0x9 or 0xD)
(2)	After the set-up time (T_s), start the conversion.
(3)	Conversion is complete in conversion time ($6 \times T_{adc}$).
(4)	The slope (gain) coefficient is calculated in the gain coefficient calculation time (T_{div}).
(5)	The GAIN registers (GAIN 0, GAIN 1, GAIN 2) are updated. At that time, RDYB bit changes from "1" to "0".
(6)	Shift to Idle state. (MODE[3:0] bit= "0x0")

The NJU 9103 supports the following two types of gain calibration operation.

A. Internal gain calibration (MODE[3:0] = 0x9)

When the internal gain calibration command is executed, the following processing is automatically performed.

- Set PGA1 to OFF and set the PGA2 gain to “x1”.
- Internally supply VREF and GND to the input of the ADC to calculate the gain coefficient.
- Store calculated gain coefficient in GAIN registers.

B. System gain calibration (MODE[3:0] = 0xD)

CHSEL [2: 0] bit selects the input channel.

When the system gain calibration command is executed, the following processing is automatically performed.

- Calculate the gain coefficient so that the input selected with the CHSEL [2: 0] bits becomes full scale.
- Store calculated gain coefficient in GAIN registers.

■ Data Calibration Flow / Combination of conversion operation and calibration operation

"Flow of data proofreading" and "Combination of conversion operation and calibration operation" are explained.

1. Single conversion or Continuous conversion

The figure below is a calibration flow block diagram of "single conversion" or "continuous conversion".

The offset calibration uses the value of the offset register (OFFSET0, OFFSET1, OFFSET2).

The gain calibration uses the values of the gain register (GAIN0, GAIN1, GAIN2).

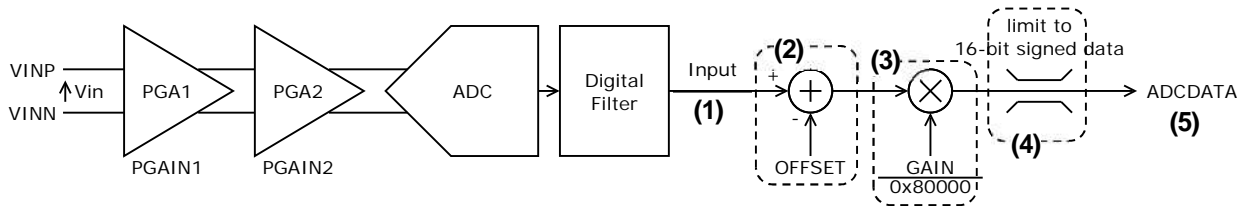

STEP	DETAILS
(1)	<p>"Input" is the following value with respect to the input voltage V_{in}. The full scale of the digital filter is eight times signed 16 bits ($262144 = 32768 \times 8$).</p> $Input = \frac{V_{in}}{VREF} \times PGAIN1 \times PGAIN2 \times 262144$
(2)	<p>Subtract "OFFSET" calculated by offset calibration operation from "Input".</p>
(3)	<p>Multiply the result of step (2) by "GAIN" calculated by the gain calibration operation. In order to convert to signed 16-bit full scale, $1 / (0x800,000) = 1 / (32768 \times 8)$ is also multiplied.</p>
(4)	<p>Confirm whether "$-32768 \leq (3) \text{ result} \leq +32768$" is satisfied. If it is not satisfied, set the OV bit of the CTRL register to "1". If it is satisfied, set the OV bit of the CTRL register to "0".</p>
(5)	<p>Store the calculation result in the ADCDATA register. If "OV=1" in step (4), the ADCDATA register is the minimum value (-32768) or the maximum value (+32767).</p> $ADCDATA = (Input - OFFSET) \times \frac{GAIN}{0x80000} = \left(\frac{V_{in}}{VREF} \times PGAIN1 \times PGAIN2 \times 262144 - OFFSET \right) \times \frac{GAIN}{0x80000}$

(Example) When applying $PGAIN1=PGAIN2=1$, $OFFSET=0$, $GAIN=0 \times 10000$, $VREF=3.3V$, $V_{in}=1V$,
 --> ADCDATA code is "9930".⁽²²⁾

$$ADCDATA = \left(\frac{1V}{3.3V} \times 1 \times 1 \times 262144 - 0 \right) \times \frac{0x10000}{0x80000} = 9930$$

(22) When thinking of NJU9103 as a black box, it is intuitively understood that it is correct.

$$ADCDATA = \frac{V_{in}}{VREF} \times PGAIN1 \times PGAIN2 \times 2^{15} = \frac{1V}{3.3V} \times 1 \times 1 \times 32768 = 9930$$

2. "Single conversion + CHOP" or "Continuous conversion + CHOP"

The figure below is a block diagram of the calibration flow of "single conversion + CHOP" or "continuous conversion + CHOP".

Since offset is removed by CHOP operation, the offset register value is not used for offset calibration.

Otherwise, it is the same operation as "1. Single conversion or continuous conversion" on the previous page.

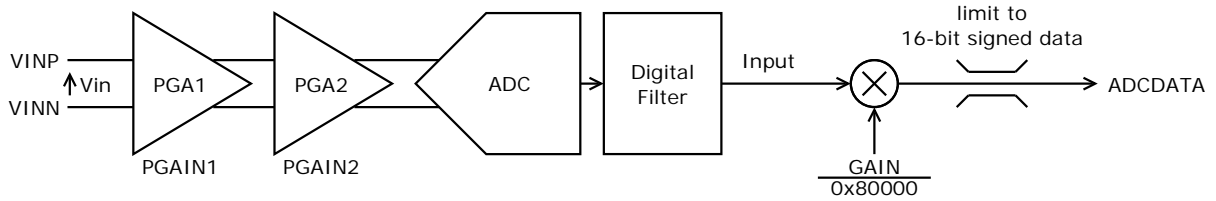

■ SPI Interface

The interface is 3-wire SPI communication of SCK, SDI, SDO / RDYB. (CSB fixed to GND inside chip)
 SDI is captured on the falling edge of SCK and SDO / RDYB is synchronized with the rising edge of SCK.
 Bits are transferred in order from the MSB.

SPI communication is performed as follows.

Step	Details
(1)	Command byte transfer
(2)	Read or write data transfer (8 bit or 16 bit data transfer)

When the data transfer is completed, it waits for the command byte.

When SPI communication is not in progress, the RDYB bit value of the CTRL register is output from SDO / RDYB.
 RDYB outputs "1" or "0" depending on the ADC operation state. (1: Conversion in progress, 0: Conversion end)

The above state is supplied from the NJU 9103 to the master device (microcomputer and others).
 Therefore, the master device can confirm the conversion end without monitoring the NJU 9103 periodically.

< Reading >

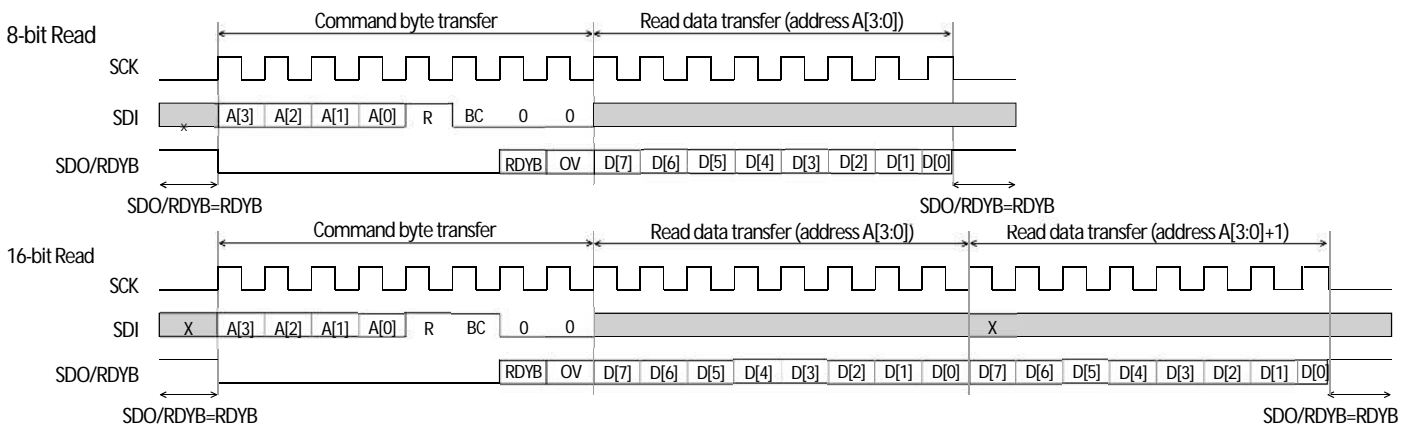

< Writing >

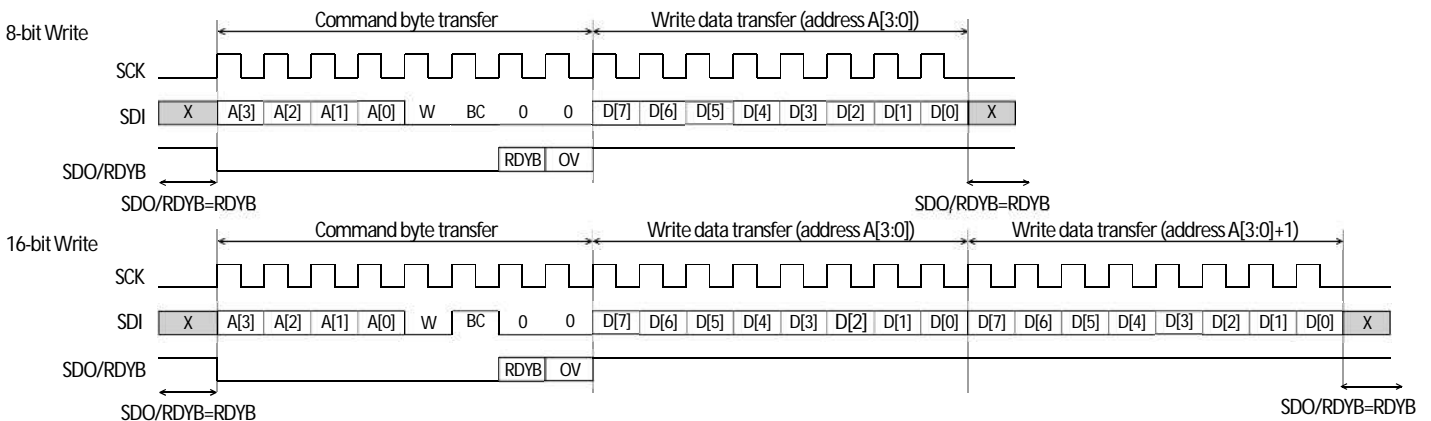

1. SPI command byte

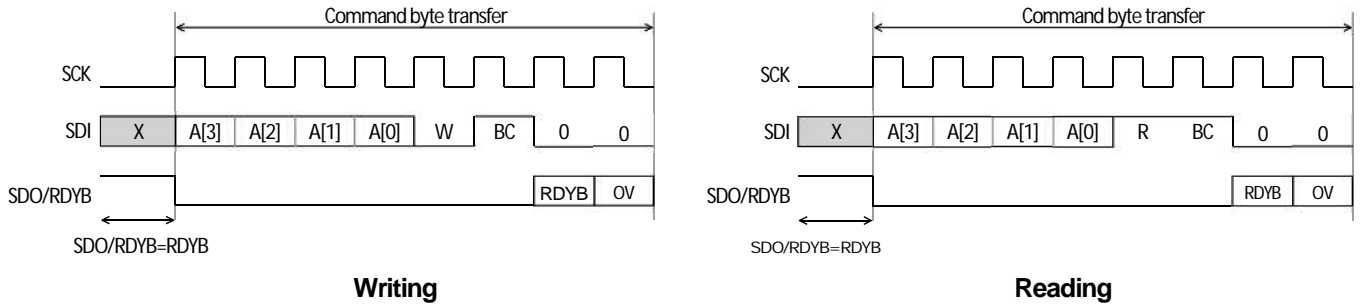

Write command (Byte)

BIT	[7]	[6]	[5]	[4]	[3]	[2]	[1]	[0]
BIT NAME	A[3:0]				RW	BC	ZERO[1:0]	
R / W	W				W	W	W	
VALUE	-				-	-	-	

BIT	BIT NAME	FUNCTION
[7:4]	A[3:0]	Specify the register address to be accessed.
[3]	RW	Specify the direction of communication. (Write or Read) 0: Write 1: Read
[2]	BC	Specify the number of access bytes. (Number of bytes of write data or read data) 0: 1byte (8bit) access 1: 2byte (16bit) access (Continuous access to "A [3: 0] bits" and "A [3: 0] bits + 1")
[1:0]	ZERO[1:0]	Always write "0"

Read command (Byte)

BIT	[7]	[6]	[5]	[4]	[3]	[2]	[1]	[0]
BIT NAME	-	-	-	-	-	-	RDYB	OV
R / W	-	-	-	-	-	-	R	R
VALUE	0	0	0	0	0	0	-	-

BIT	BIT NAME	FUNCTION
[1]	RDYB	Returns the same value as the RDYB bit of the CTRL register
[0]	OV	Returns the same value as the OV bit of the CTRL register

2. SPI reset command

Transferring SDI=1 continuously for 23 bits after SDI=0 resets the chip.

In normal operation, since there is "0" in the ZERO [1: 0] bits of the SPI command byte, SDI=1 never becomes 23 consecutive bits.

Wait at least 400 ns after reset and transfer the command byte of operation start. 400 ns is the minimum required for internal startup time.

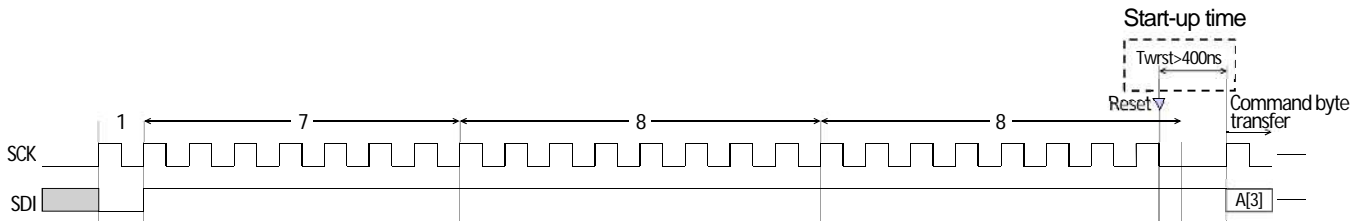

3. SPI communication example

< Single conversion >

This is an example of communication with the PGA gain setting implemented. (Processing in the shortest time)

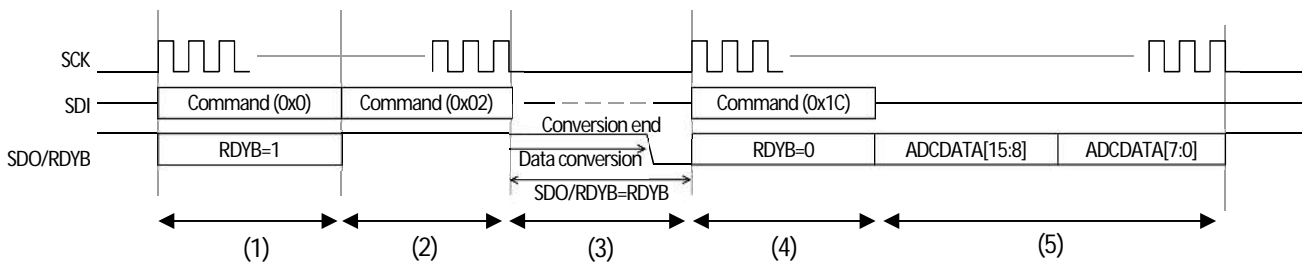

STEP	DETAILS
(1)	Specify the address "0x0" of the CTRL register.
(2)	Specify single conversion "0x2" (= MODE [3: 0]).
(3)	Performs single conversion. (Conversion time + setup time + data correction time (= 1 / DR + Ts + Tcal))
(4)	Specify the ADCDATA0 register (0x1).
(5)	Read the conversion data (ADCDATA0 register and ADCDATA1 register).

The table below shows the time when CLKDIV = 0 and the operation clock of SPI is 5 Mbps. It is understood that the time of SPI communication << conversion time.

OSR	Conversion time (1/DR+Ts+Tcal) [μs]	SPI communication time ((1)+(2)+(4)+(5)) [μs]
512	1255	8 (= 1/(5[Mbit/s]) x 5[byte] x 8[bit/byte])
256	640	
128	333	
64	180	

< Continuous conversion >

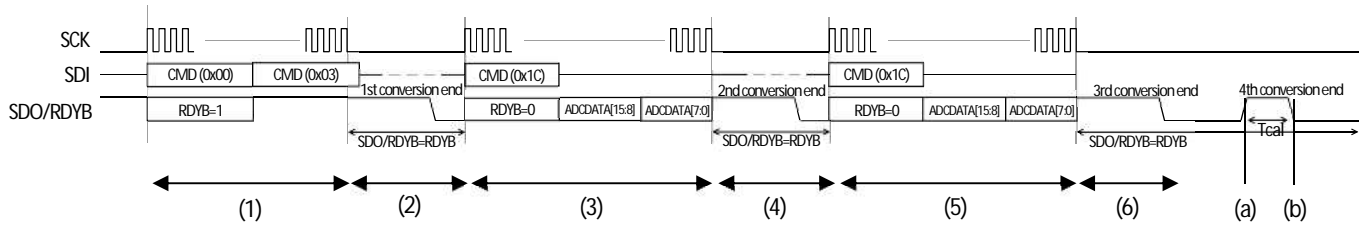

STEP	DETAILS
(1)	Specify the address "0x0" of the CTRL register and specify continuous conversion "0x3" (= MODE [3:0]).
(2)	Perform continuous conversion (first time). After conversion, SDO / RDYB changes from "1" to "0".
(3)	Specify the address "0x1" of the ADCDATA0 register. SDO / RDYB changes from "0" to "1" when conversion data (ADCDATA0 register and ADCDATA1 register) is read.
(4)	Perform continuous conversion (second time). After conversion, SDO / RDYB changes from "1" to "0".
(5)	Specify the address "0x1" of the ADCDATA0 register. SDO / RDYB changes from "0" to "1" when conversion data (ADCDATA0 register and ADCDATA1 register) is read.
(6)	Perform continuous conversion (third time). After conversion, SDO / RDYB changes from "1" to "0".
(7)	:

SDO / RDYB is kept "0" when reading the third conversion result is not performed.

If reading is not performed, it operates as follows.

- (a) SDO / RDYB changes from "0" to "1" when the fourth AD conversion before data correction ends.
- (b) After the data correction time (Tcal), SDO / RDYB changes from "1" to "0".

At the point (a) above, the third conversion data is discarded.

If conversion data (ADCDATA0 / ADCDATA1 register) is not read before the next (a) comes, the fourth data is also discarded. In order to read data safely, it is necessary to read the conversion data before (a) comes.

■ Analog input range and ADC output code

1. Analog input 1 of ELECTRICAL CHARACTERISTICS (Analog Input)

PGA 1 is OFF, only PGA 2 can be used.
It is an image as shown on the right.

1. Case of VDD = VREF = 3.3 V

With VREF = 3.3 V, the ADC full-scale input voltage range is 6.6V (3.3 V).

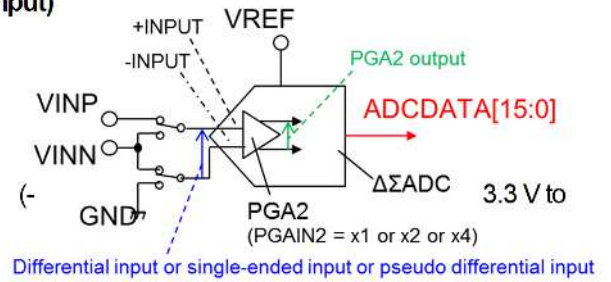

Differential input

By setting the CHSEL [2: 0] bit of the CTRL register to "0x0", the +INPUT set to VINP and the -INPUT is set to VINN.

● Case of PGAIN2=1

Input voltages VINP and VINN, it can be input the voltage amplitude of up to 1.65V with 1.65V as the center.

The differential input "VINP - VINN" is ±3.3 V, the PGA2 output is also ±3.3V and the conversion data is -32768 to +32767 (full scale).

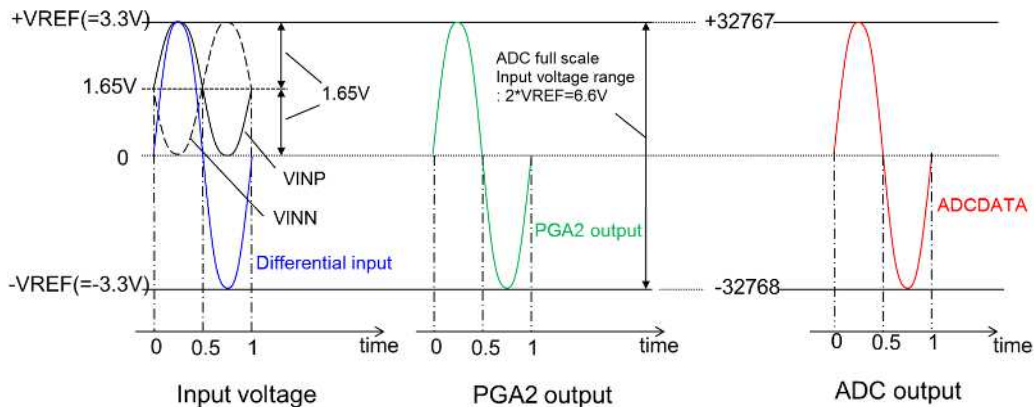

● Case of PGAIN2=2 or 4

When PGAIN2=2, it can be input voltage amplitude of up to 0.825V. (1/2 of when PGAIN 2=1)

When PGAIN2=4, it can be input voltage amplitude of up to 0.4125V. (1/4 of when PGAIN2=1)

The figure below shows the case of PGAIN 2=2. The differential input "VINP - VINN" is ±1.65 V, the PGA2 output is ±3.3 V, and the conversion data is -32768 to +32767 (full scale).

The differential input range 1 (VDIN1) of the electrical characteristics is the calculation formula on the right.

$$VDIN1 = \pm VREF / (PGAIN2)$$

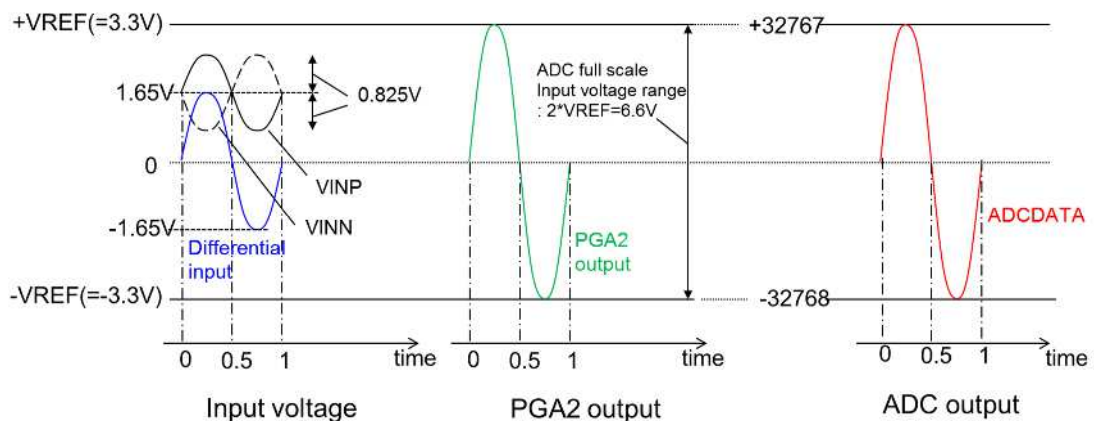

Single-ended input

By setting the CHSEL [2: 0] bit of the CTRL register to "0x2" or "0x3", the +INPUT set to VINP (0x2) or VINN (0x3), and the -INPUT is set to GND.

- **Case of PGAIN2=1**

Input voltages are VINP or VINN, it can be input the voltage amplitude of up to 1.65 V with 1.65 V as the center. The single-ended input VINP or VINN is 0V to 3.3 V, the PGA2 output is also 0V to 3.3V, and the conversion data is 0 to +32767 (Half full scale).

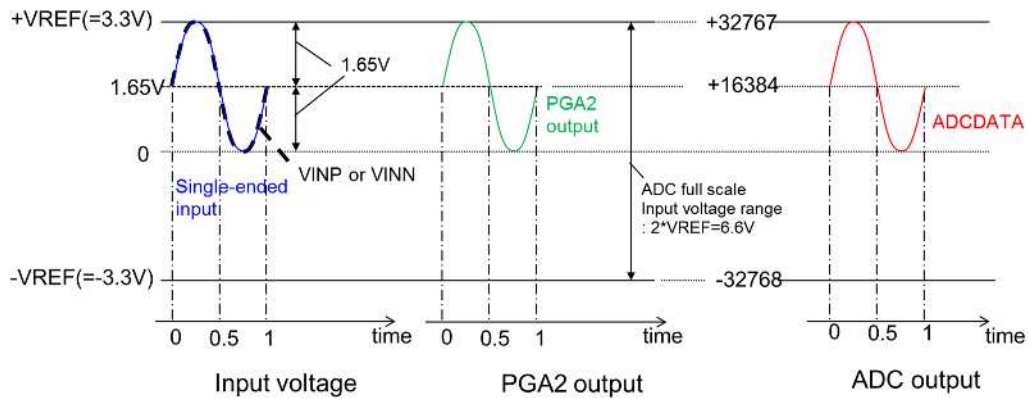

- **Case of PGAIN2=2 or 4**

As with differential input, the input amplitude is 1/2, 1/4 when PGAIN2=1.

Pseudo-differential input

By setting the CHSEL [2: 0] bit of the CTRL register to "0x0", the +INPUT set to VINP and the -INPUT is set to VINN. (VINN=1.65V)

- **Case of PGAIN2=1**

Input voltages are VINP and VINN, it can be input the voltage amplitude of up to 1.65 V with 1.65 V as the center. The pseudo-differential input "VINP-VINN" is $\pm 1.65V$, the PGA2 output is also $\pm 1.65V$ and the conversion data is -16384 to +16384 (Half full scale).

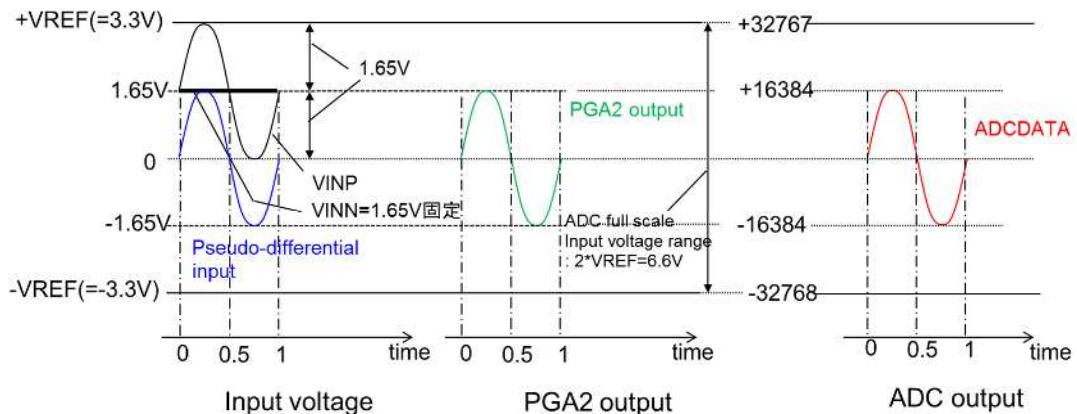

- **Case of PGAIN2=2 or 4**

As with differential input, the input amplitude is 1/2, 1/4 when PGAIN2=1.

2. Analog input 2 of ELECTRICAL CHARACTERISTICS (Analog Input)

Both PGA 1 and PGA 2 can be used.
 PGAIN 2 = 1.
 It is an image as shown on the right.

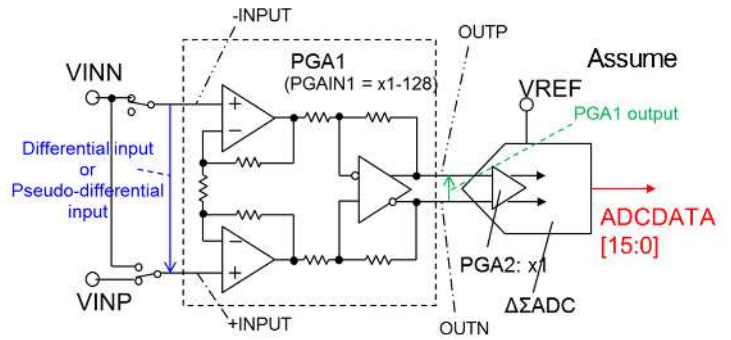

(1) Case of VDD=VREF=3.3V, Input bias=1.65V

Differential input

By setting the CHSEL [2: 0] bit of the CTRL register to "0x0", the +INPUT set to VINP, and the -INPUT is set VINN.

• Case of PGAIN1=1

The ideal maximum input range is $0.5 \times VREF / 1 = 1.65 \text{ V}$.

However, the signal amplitude that can be input is limited by the input D-range of PGA 1.

Since the common mode input range of PGA 1 is 0.1 V to 2.1 V ($VDD - 1.2 \text{ V}$), the maximum amplitude of VINP and VINN is $2.1 \text{ V} - 1.65 \text{ V} = 0.45 \text{ V}$.

The differential input "VINP - VINN" is $\pm 0.9 \text{ V}$, the PGA1 output is also $\pm 0.9 \text{ V}$ and the conversion data is -8937 to +8937 by the following calculation formula.

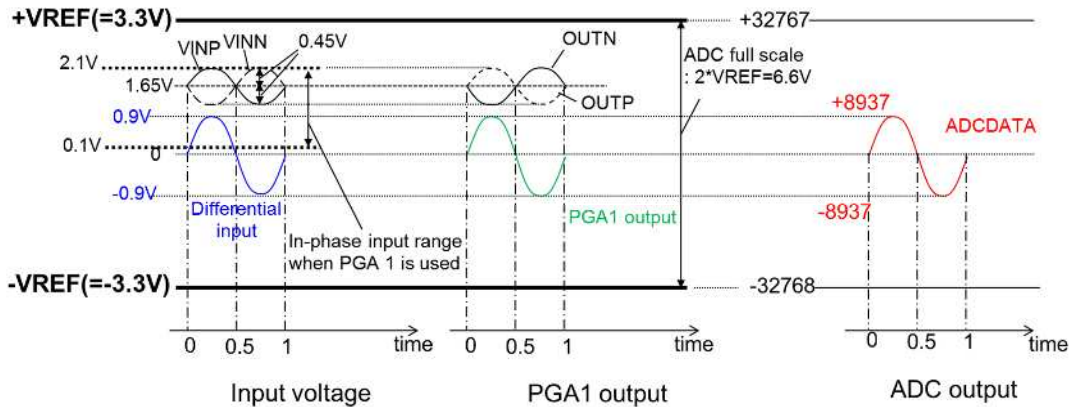

$$ADCDATA = \frac{V_{in}}{VREF} \times PGAIN1 \times PGAIN2 \times 2^{15} = \frac{\pm 0.9 \text{ V}}{3.3 \text{ V}} \times 1 \times 1 \times 32768 = \pm 8937$$

• **Case of PGAIN1=2**

The maximum amplitude of VINP and VINN is 0.45 V because of "maximum amplitude 0.45V due to input D-range constraint" < "ideal maximum input amplitude: 0.5 x VREF / 2 = 0.875 V".

The differential input "VINP - VINN" is ±0.9V, the PGA1 output is also ±1.8V and the conversion data is -17873 to +17873 by the following calculation formula.

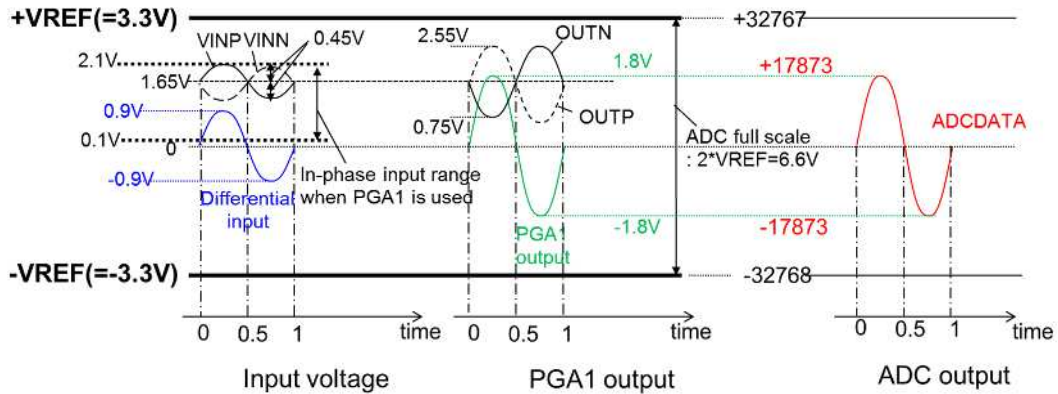

$$ADCDATA = \frac{V_{in}}{VREF} \times PGAIN1 \times PGAIN2 \times 2^{15} = \frac{\pm 0.9V}{3.3V} \times 2 \times 1 \times 32768 = \pm 17873$$

• **Case of PGAIN1=4**

The input D-range is not restricted because of "Input D-range limit of PGA1: 2.1 V - 1.65 V = 0.45 V" > "Ideal maximum input amplitude: 0.5 x VREF / 4 = 0.4125 V".

However, this time it is subject to the limit of the amplifier output D-range ("GND + 0.1 V" to "VDD - 0.1 V" range). The maximum amplitude of OUPP and OUPN of the PGA1 output is 0.5 x VDD - 0.1 = 1.55 V.

The maximum amplitude of VINP and VINN is 1.55 V / 4 = 0.3875 V.

The differential input is ±0.775V, the PGA1 output is ±3.1V (=±0.775V x4) and the conversion data is -30782 to +30782 by the following calculation formula.

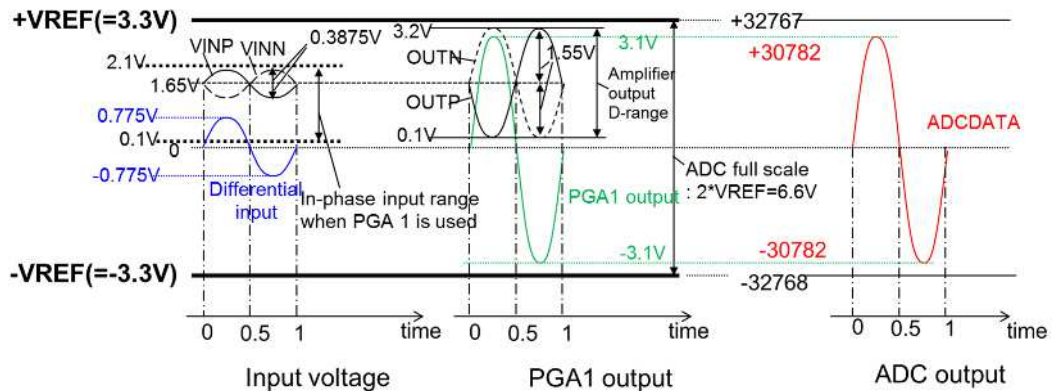

$$ADCDATA = \frac{V_{in}}{VREF} \times PGAIN1 \times PGAIN2 \times 2^{15} = \frac{\pm 0.775V}{3.3V} \times 4 \times 1 \times 32768 = \pm 30782$$

- **Case of PGAIN1 = 8, 16, 32, 64, 128:** See the table below

The table below shows the correspondence between maximum input amplitude, differential input voltage and conversion data when "VDD = VREF = 3.3V, bias voltage = 0.5 x VDD = 1.65V".

PGAIN1	Maximum input amplitude [V]	Differential input voltage [V]	Conversion data (ADCDATA0/1 register)
1	2.1-0.5*VDD = 0.45	$\pm(\text{Maximum input amplitude}) * 2$	± 8937
2			± 17873
4	$(0.5 * VDD - 0.1) / (\text{PGAIN1})$	$\pm(0.5 * VDD - 0.1) / (\text{PGAIN1}) * 2$	± 30782
8			
16			
32			
64			
128			

Pseudo-differential input

By setting the CHSEL [2: 0] bit of the CTRL register to "0x0", the +INPUT set to VINP, and the -INPUT is set VINN.

The basic operation and restrictions are the same as in , and the conversion data is half of .

(2) Case of VDD=3.3V, VREF=0.5 x VDD = 1.65V

Differential input

By setting the CHSEL [2: 0] bit of the CTRL register to "0x0", the +INPUT set to VINP, and the -INPUT is set VINN.

• Case of PGAIN1 = 1

In the "D-range limit of PGA1 input: 2.1V - 1.65V = 0.45V" < "input signal maximum amplitude: VREF x 0.5 = 0.825V", the input signal is limited by the D-range of the PGA1 input stage (instrumentation amplifier).

The differential input is ±0.9V, the PGA2 output is ±0.9V and ADCDATA is -17873 to +17873 by the following calculation formula.

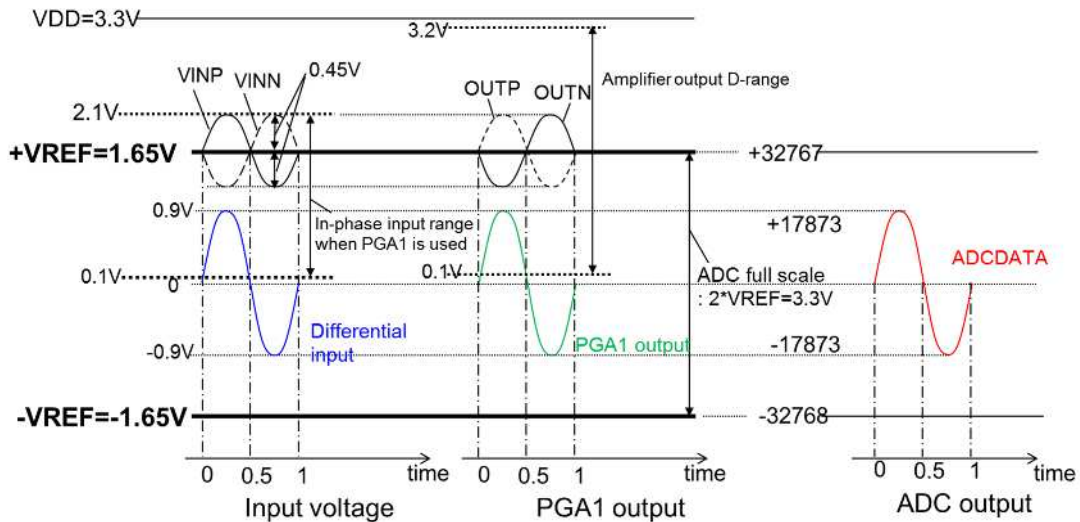

$$ADCDATA = \frac{V_{in}}{VREF} \times PGAIN1 \times PGAIN2 \times 2^{15} = \frac{\pm 0.9}{1.65V} \times 1 \times 1 \times 32768 = \pm 17873$$

• Case of PGAIN1 = 2

The input D-range is not restricted by 'Input D-range limit of PGA1: 2.1V - 1.65V = 0.45V' > 'Maximum amplitude of input signal: VREF x 0.5 / 2 = 0.4125V'.

Since it is not affected by the D range of the amplifier output side, it is possible to use the full scale of the ADC.

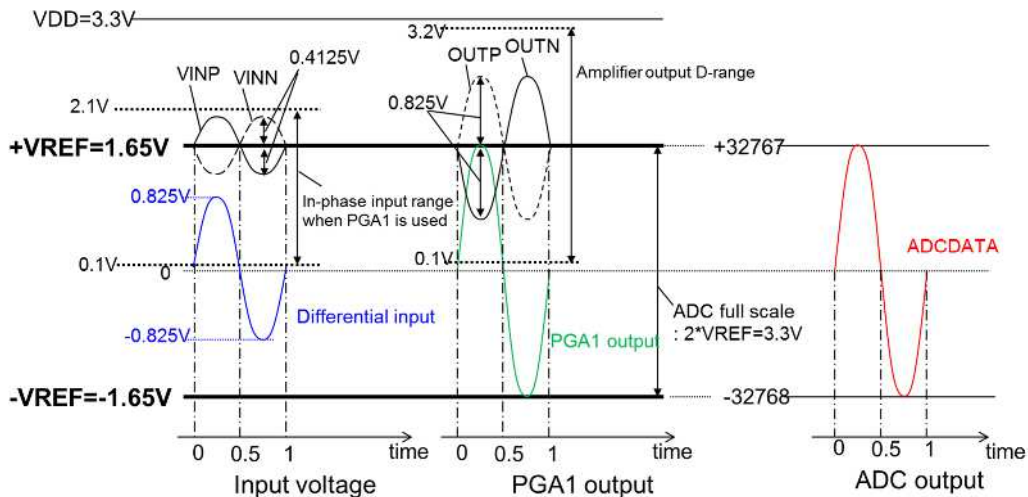

The table below shows the correspondence between maximum input amplitude, differential input voltage and conversion data when "VDD = 3.3V, VREF = 0.5V x VDD = 1.65V, bias voltage = 0.5 x VDD = 1.65V".

PGAIN1	Maximum input amplitude [V]	Differential input voltage [V]	Conversion data (ADCDATA0/1 register)
1	2.1 - 0.5 x VDD = 0.45	$\pm(\text{Maximum input amplitude}) \times 2$	± 17873
2	0.5 x VREF / PGAIN1	$\pm VREF / PGAIN1$	-32768 to +32767
4			
8			
16			
32			
64			
128			

Pseudo-differential input

By setting the CHSEL [2: 0] bit of the CTRL register to "0x0", the +INPUT set to VINP, and the -INPUT is set VINN. The VINN (-INPUT) is fixed at "0.5 x VDD".

The basic operation and restrictions are the same as in , and the conversion data is half of .

■ EVALUATION BOARD · PCB LAYOUT

NJU9103 evaluation board is composed of three boards.

- Board1 : Microcomputer board (NUCLEO-F411RE / ST Microelectronics)
- Board2 : NJU9103 board (Mount Circuit component)
- Board3 : NJU9103 socket board (Convert from DFN8 (ESON8-V1) to DIP 8 or from SSOP8 to DIP8)



Board1



Board2



Board3



Board 2 circuit diagram

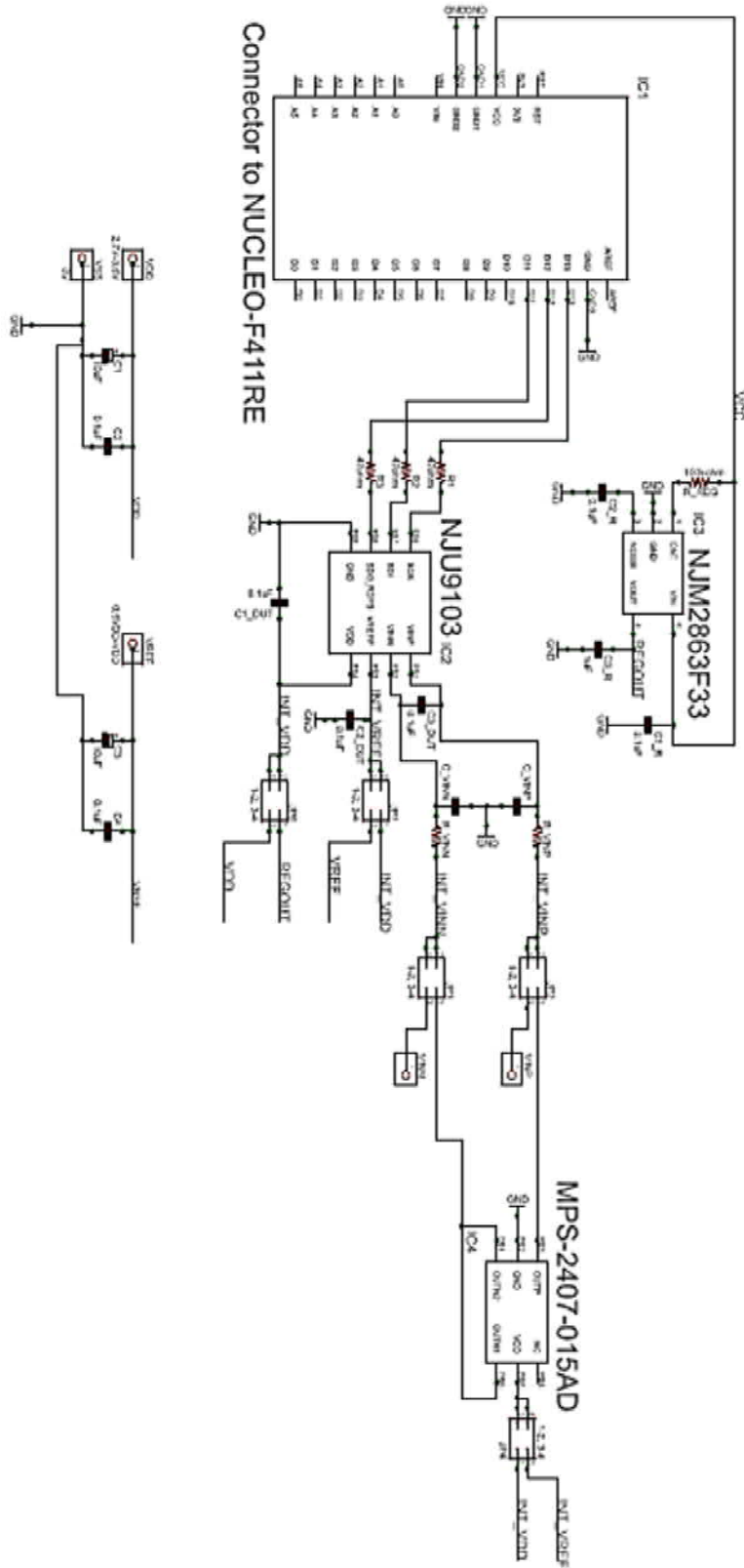

外形寸法図

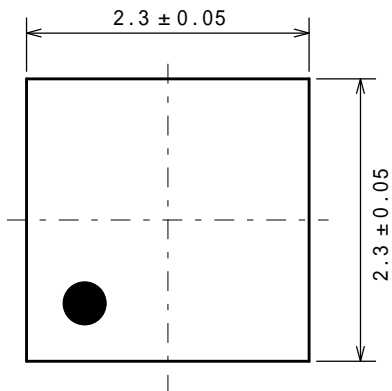

フットパターン

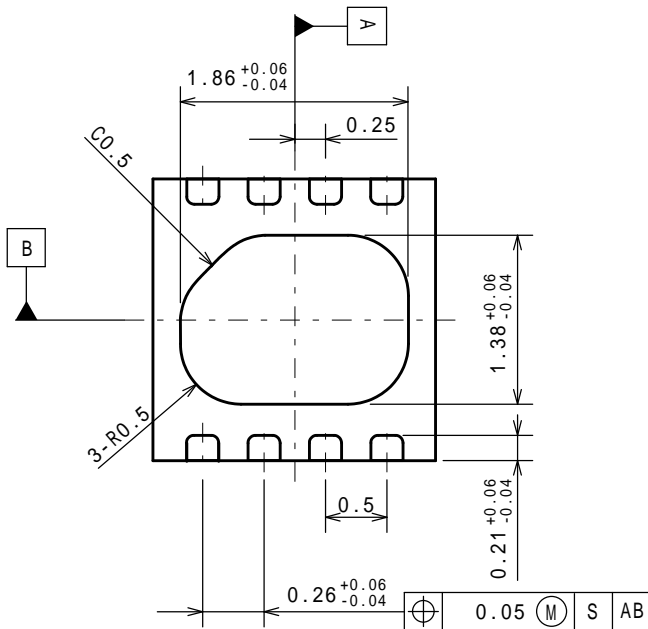
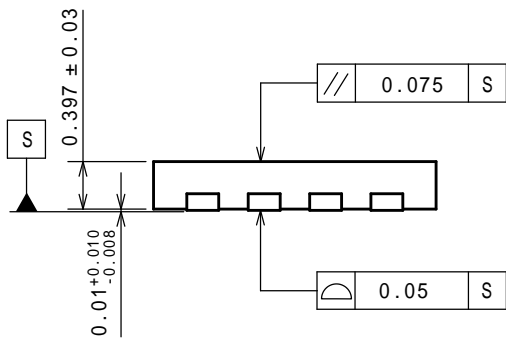
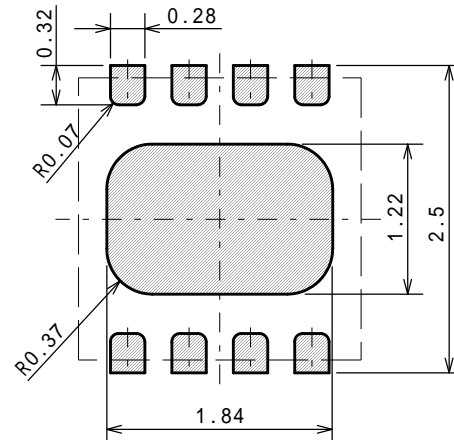

PACKAGE DIMENSIONS

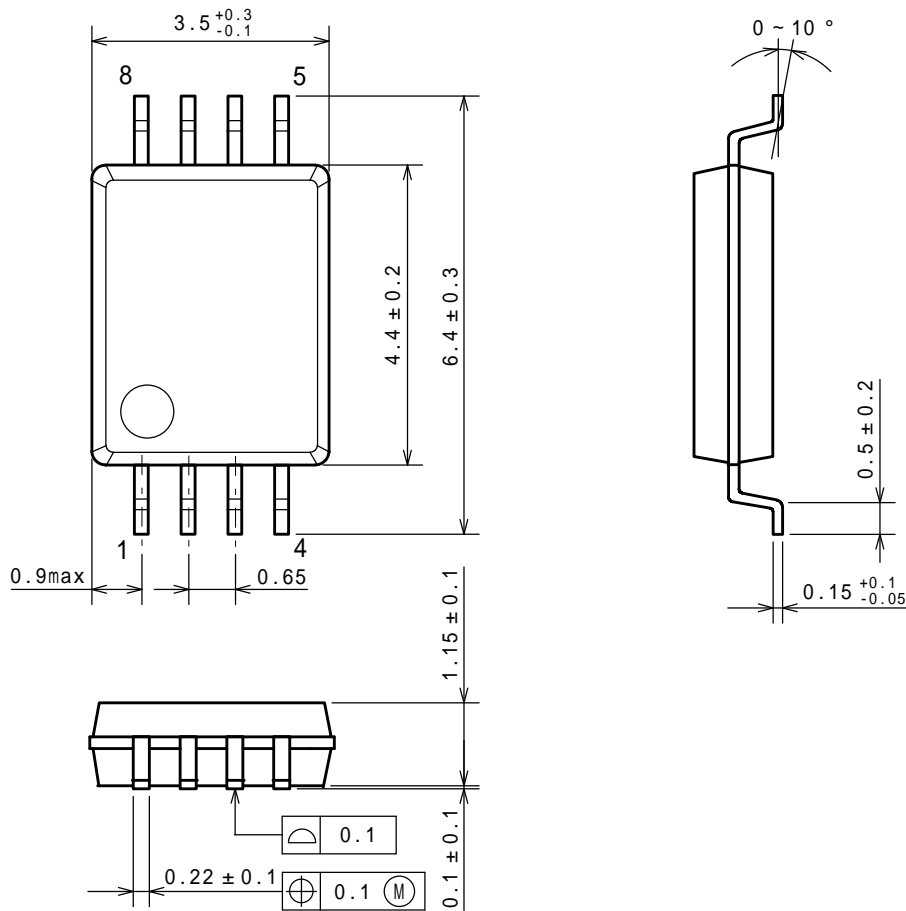

EXAMPLE OF SOLDER PADS DIMENSIONS

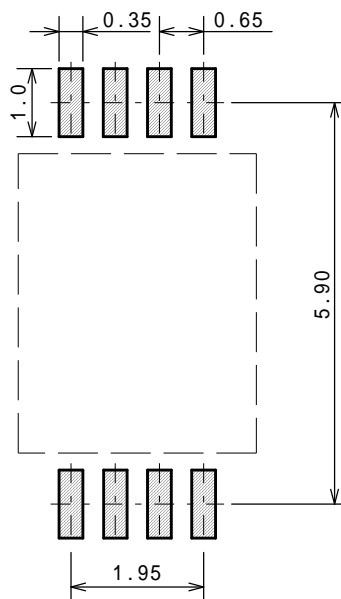

PACKING SPEC

TAPING DIMENSIONS

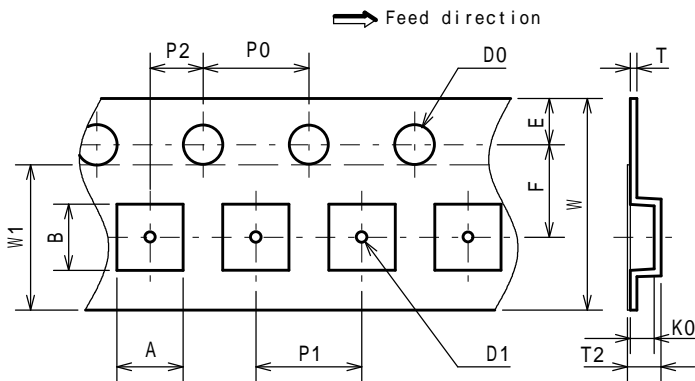

SYMBOL	DIMENSION	REMARKS
A	2.55 ± 0.05	BOTTOM DIMENSION
B	2.55 ± 0.05	BOTTOM DIMENSION
D0	1.5 ^{+0.1} ₀	
D1	0.5 ± 0.1	
E	1.75 ± 0.1	
F	3.5 ± 0.05	
P0	4.0 ± 0.1	
P1	4.0 ± 0.1	
P2	2.0 ± 0.05	
T	0.25 ± 0.05	
T2	1.00 ± 0.07	
K0	0.65 ± 0.05	
W	8.0 ± 0.2	
W1	5.5	THICKNESS 0.1max

REEL DIMENSIONS

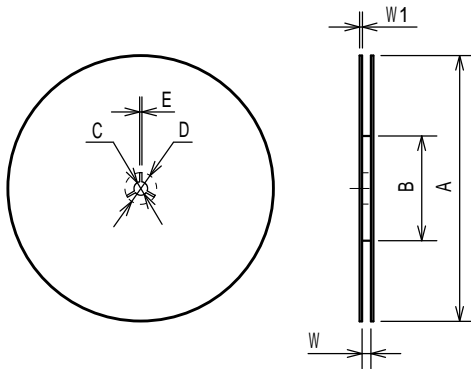

SYMBOL	DIMENSION
A	180 ⁰ _{-1.5}
B	60 ⁺¹ ₀
C	13 ± 0.2
D	21 ± 0.8
E	2 ± 0.5
W	9 ^{+0.3} ₀
W1	1.2

TAPING STATE

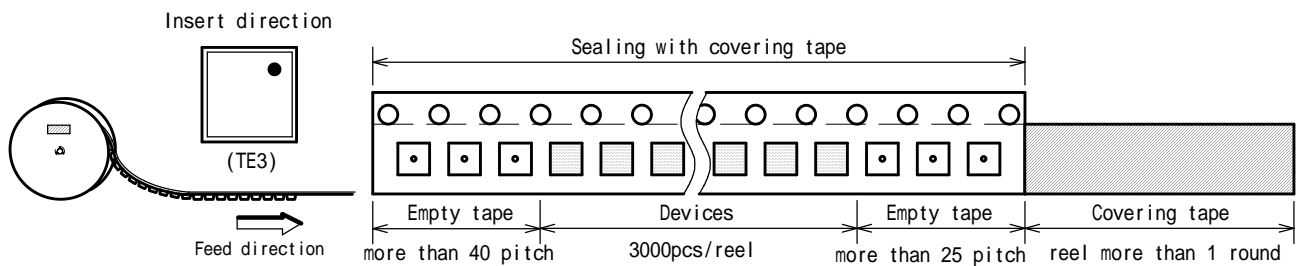

PACKING STATE

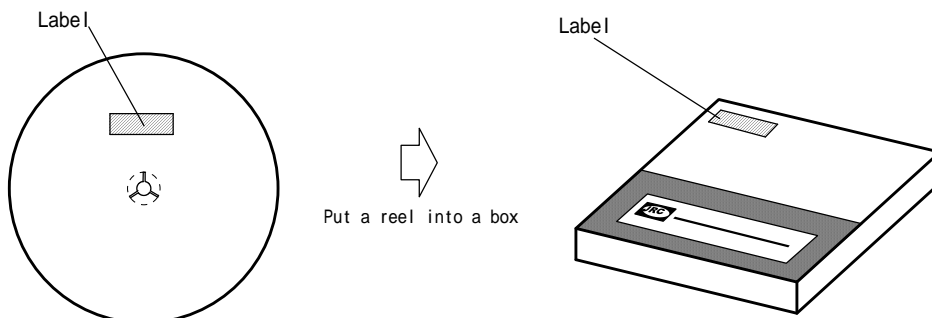

PACKING SPEC

TAPING DIMENSIONS

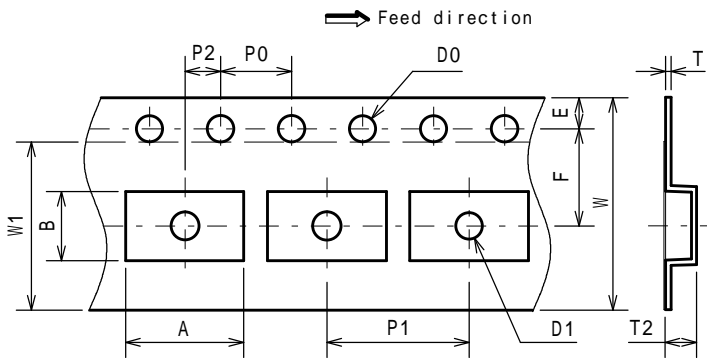

SYMBOL	DIMENSION	REMARKS
A	6.7	BOTTOM DIMENSION
B	3.9	BOTTOM DIMENSION
D0	1.55 ± 0.05	
D1	1.55 ± 0.1	
E	1.75 ± 0.1	
F	5.5 ± 0.05	
P0	4.0 ± 0.1	
P1	8.0 ± 0.1	
P2	2.0 ± 0.05	
T	0.3 ± 0.05	
T2	2.2	
W	12.0 ± 0.3	
W1	9.5	THICKNESS 0.1max

REEL DIMENSIONS

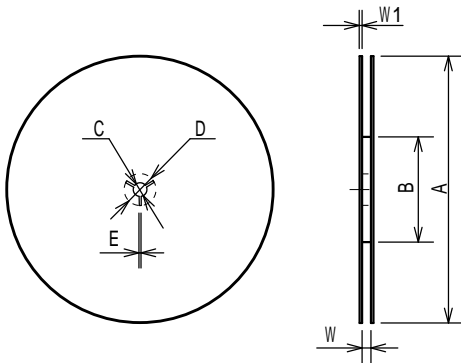

SYMBOL	DIMENSION
A	254 ± 2
B	100 ± 1
C	13 ± 0.2
D	21 ± 0.8
E	2 ± 0.5
W	13.5 ± 0.5
W1	2 ± 0.2

TAPING STATE

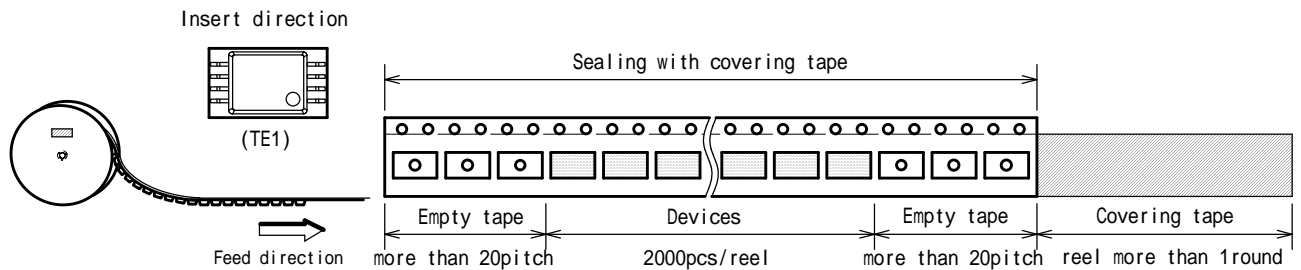

PACKING STATE

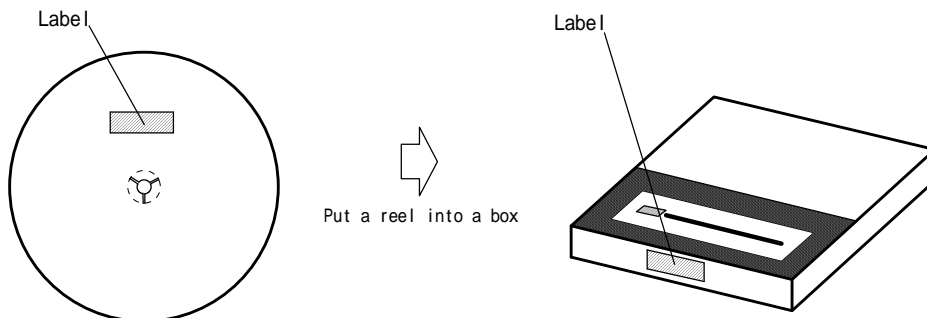

RECOMMENDED MOUNTING METHOD

Flow / Reflow of correspondence are shown in the following.

Package	Flow	Reflow
DFN8 (ESON8-V1)	NG	OK
SSOP8	OK	OK

- Flow soldering procedure

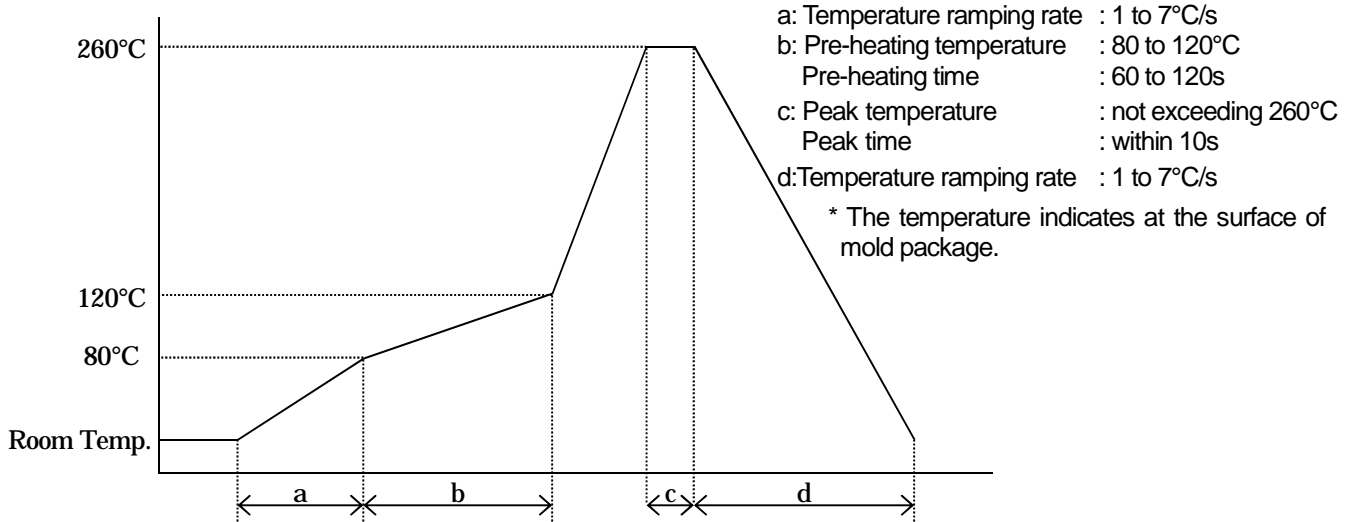

- Recommended reflow soldering procedure

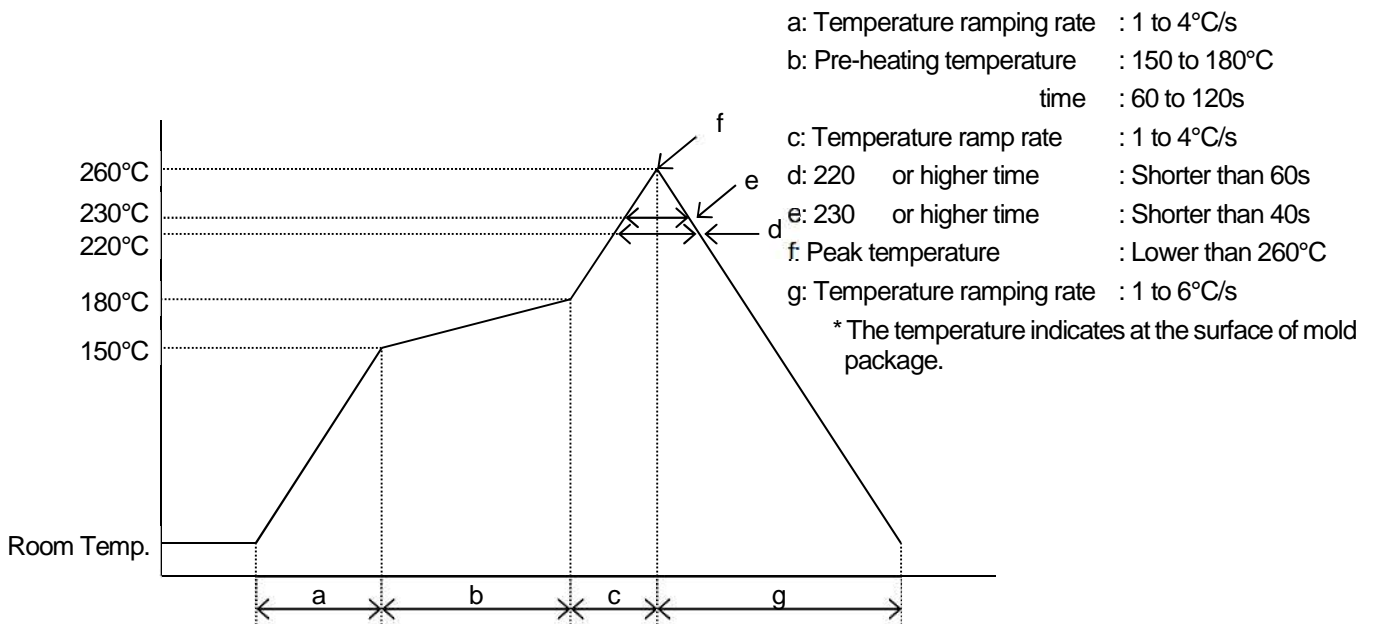

[CAUTION]

1. New JRC strives to produce reliable and high quality semiconductors. New JRC's semiconductors are intended for specific applications and require proper maintenance and handling. To enhance the performance and service of New JRC's semiconductors, the devices, machinery or equipment into which they are integrated should undergo preventative maintenance and inspection at regularly scheduled intervals. Failure to properly maintain equipment and machinery incorporating these products can result in catastrophic system failures
2. The specifications on this datasheet are only given for information without any guarantee as regards either mistakes or omissions. The application circuits in this datasheet are described only to show representative usages of the product and not intended for the guarantee or permission of any right including the industrial rights.
All other trademarks mentioned herein are property of their respective companies.
3. To ensure the highest levels of reliability, New JRC products must always be properly handled.
The introduction of external contaminants (e.g. dust, oil or cosmetics) can result in failures of semiconductor products.
4. New JRC offers a variety of semiconductor products intended for particular applications. It is important that you select the proper component for your intended application. You may contact New JRC's Sale's Office if you are uncertain about the products listed in this catalog.
5. Special care is required in designing devices, machinery or equipment which demand high levels of reliability. This is particularly important when designing critical components or systems whose failure can foreseeably result in situations that could adversely affect health or safety. In designing such critical devices, equipment or machinery, careful consideration should be given to amongst other things, their safety design, fail-safe design, back-up and redundancy systems, and diffusion design.
6. The products listed in the catalog may not be appropriate for use in certain equipment where reliability is critical or where the products may be subjected to extreme conditions. You should consult our sales office before using the products in any of the following types of equipment.

Aerospace Equipment
Equipment Used in the Deep sea
Power Generator Control Equipment (Nuclear, Steam, Hydraulic)
Life Maintenance Medical Equipment
Fire Alarm/Intruder Detector
Vehicle Control Equipment (airplane, railroad, ship, etc.)
Various Safety devices

7. New JRC's products have been designed and tested to function within controlled environmental conditions. Do not use products under conditions that deviate from methods or applications specified in this catalog. Failure to employ New JRC products in the proper applications can lead to deterioration, destruction or failure of the products. New JRC shall not be responsible for any bodily injury, fires or accident, property damage or any consequential damages resulting from misuse or misapplication of its products. Products are sold without warranty of any kind, either express or implied, including but not limited to any implied warranty of merchantability or fitness for a particular purpose.
8. Warning for handling Gallium and Arsenic(GaAs) Products (Applying to GaAs MMIC, Photo Reflector). This Products uses Gallium(Ga) and Arsenic(As) which are specified as poisonous chemicals by law. For the prevention of a hazard, do not burn, destroy, or process chemically to make them as gas or power. When the product is disposed, please follow the related regulation and do not mix this with general industrial waste or household waste.
9. The product specifications and descriptions listed in this catalog are subject to change at any time, without notice.

